

LIGHT POWER HARROW

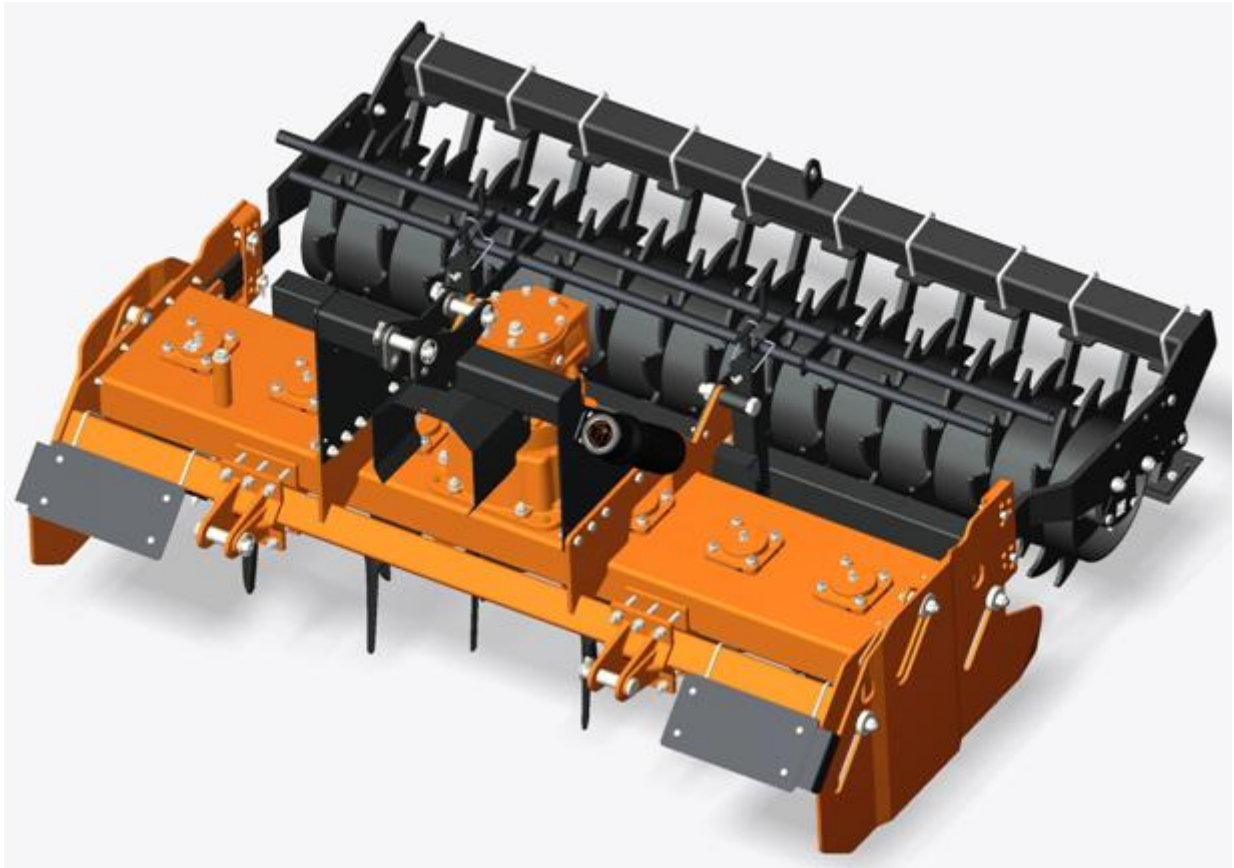

OPERATOR'S AND PARTS MANUAL

Tirth Agro Technology Pvt. Ltd.
(An ISO 9001:2015 & CE Certified Company)



OM1212-31EN-000_18

Congratulation for purchasing your new **SUNDOWN LIGHT POWER HARROW!**

This machine has been designed and manufactured following all safety and quality requirements needed for a safe and satisfactory use over time.

A careful reading of this manual will permit you to familiarize with your new equipment, and will provide you all the tools needed to use it safely.

A proper maintenance and knowledge of the safety rules of use will allow obtaining the best performance and a long service life of the machine.



The Safety Alert Symbol used throughout this manual and on safety decals of the machine indicates the presence of potential hazard to the operator. When you see this symbol, be alert and carefully read the message that follows it.

The Safety Alert Symbol is used in conjunction with following Signal Words, according to the degree of possible injuries that may result operating the implement:



DANGER

Indicate an imminently hazardous situation that, if not avoided, will result in death or serious injury.



WARNING

Indicates a potentially hazardous situation that, if not avoided, could result in death or serious injury, and includes hazards that are exposed when guards are removed. It may also be used to alert against unsafe practices.



CAUTION

Indicate a potentially hazardous situation that, if not avoided, may result in minor or moderate injury. It may also be used to alert against unsafe practices.

IMPORTANT

Indicate instructions or procedures that, if not observed, can cause damage to equipment or environment.

NOTE

Indicate helpful information.

READ, UNDERSTAND, and FOLLOW the safety messages following the Safety Alert Symbol and Signal Words. Failure to comply with safety messages could result in serious bodily injury or death.

TO THE PURCHASER

This manual contains valuable information about **SUNDOWN LIGHT POWER HARROW**. It has been carefully prepared to give you helpful suggestions for operating, adjusting, servicing repair parts.

Keep this manual in a convenient place for quick and easy reference. Study it carefully. You have purchased a dependable and sturdy **power harrow**, but only by proper care and operation can you expect to get the service and long life designed and built into it.

RIGHT-HAND AND LEFT-HAND sides are determined by watching from the tractor side.

Sometime in the future your **power harrow** may need new parts to replace those are worn or broken. If so, go to nearest **SUNDOWN** dealer and provide him the model and part number.

Customer information

Name _____

Purchased from _____

Purchased date _____

Model No. _____

Serial No. _____

TABLE OF CONTENTS

1.	ABOUT THIS MANUAL.....	1
2.	INTRODUCTION	1
2.1.	IDENTIFICATION	1
2.2.	INTENDED USE.....	2
2.3.	MAIN PARTS DESCRIPTION	3
2.4.	REAR ROLLERS.....	4
2.5.	TECHNICAL SPECIFICATIONS.....	5
3.	SAFETY.....	6
3.1.	GENERAL SAFETY INSTRUCTIONS	6
3.2.	EQUIPMENT SAFETY INSTRUCTIONS	7
3.3.	OPERATING SAFETY INSTRUCTIONS	8
3.4.	TRANSPORTING SAFETY INSTRUCTIONS.....	10
3.5.	MAINTENANCE SAFETY INSTRUCTIONS	11
3.6.	STORAGE SAFETY INSTRUCTIONS	12
3.7.	SAFETY LABELS.....	13
	SAFETY LABELS POSITION AND DESCRIPTION	13
4.	SET-UP	17
4.1.	HANDLING	17
4.2.	BARCKET PINS(LOWER HITCHES)CHECK.....	18
4.3.	CONNECTING TO THE TRACTOR	19
4.4.	DRIVELINE INSTALLATION	20
	DRIVELINE LENGTH CHECK.....	21
4.5.	HYDRAULIC CONNECTION	22
	CONNECTION OF ADDITIONAL IMPLEMENTS.....	23
4.6.	TRACTOR-MACHINE STABILITY.....	24
4.7.	TRANSPORT	25
5.	OPERATING	26
5.1.	START UP AND REUSING.....	26
5.2.	OPERATING INSTRUCTIONS.....	27
5.3.	ADJUSTMENTS	29
	WORKING DEPTH ADJUSTMENT	29

ROLLER ADJUSTMENT BY PIN	29
LEVELLING BAR ADJUSTMENT	31
SIDE PLATE ADJUSTMENT	32
FRICTION CLUTCH ADJUSTMENT.....	33
5.4. STOPPING AND DISCONNECTION.....	34
5.5. TRANSPORT	35
6. MAINTENANCE	36
6.1. TOOLS REPLACEMENT	37
FITTING PATTERN OF BLADES	39
6.2. SCRAPER PLATES REPLACEMENT (PACKER ROLLER).....	40
6.3. GEARBOX LUBRICATION.....	41
6.4. GEARS TROUGH LUBRICATION.....	42
6.5. REAR ROLLER BEARINGS LUBRICATION	43
6.6. SECONDARY DRIVE BEARING AND LEVELING BAR SCREW LUBRICATION.....	44
6.7. DRIVESHAFT MAINTENANCE.....	45
7. STORAGE.....	46
8. SCRAPPING.....	46
9. TROUBLESHOOTING	47
10. TORQUE VALUES TABLE	49
11. WARRANTY	50
12. SPARE PARTS.....	53

1. ABOUT THIS MANUAL

The operator must read the manual for a correct understanding of the hazards that may present when operating the power harrow ("the machine"), as well as for obtain optimum performance from the machine.

The manual is part of the machine, it must be kept in good condition and remain with the machine even in case of resale, until its demolition. In case of loss or damage, request a new copy to the Manufacturer or your Dealer.

The information, descriptions and illustrations in this manual describe the state of the product at the time of its publication, and may not reflect the product in the future.

The Manufacturer reserve the right to make design improvements or changes in specifications without incurring in any obligation to install them on units previously sold.

Text, illustrations and drawings of this manual cannot be disclosed or transmitted, in whole or in part, to third parties without the written permission of the Manufacturer. All rights are reserved.

2. INTRODUCTION

2.1. IDENTIFICATION

Each machine is provided with a plate for unique identification (see picture below), showing the CE marking together with following information:

- Manufacturer name and address
- Type of machine ("TYPE")
- Model of machine ("MODEL")
- Serial number ("SERIAL No.")
- Construction year ("YEAR")
- Machine weight ("MASS")
- Speed required at Implement Input Connection ("INPUT").

It's recommended to note down all data shown on the plate.

Any request for assistance or information regarding the machine must be directed to the Manufacturer or Dealer always referring to the model and serial number as shown on the plate affixed to the machine.

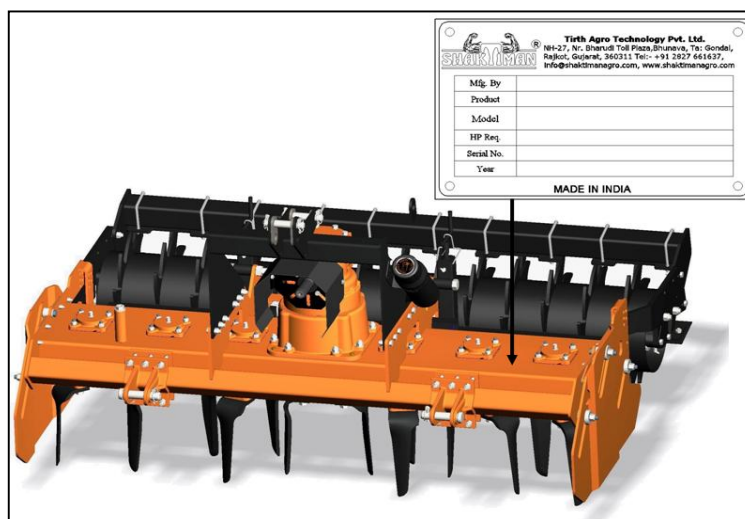

2.2. INTENDED USE

The **power harrow machines** specifically designed for agricultural application, and are intended to be used to refine the soil and prepare the seedbed.

The machine, mounted on the tractor by means of the hydraulic three-point linkage, operates on the ground thanks to its own weight and to the dynamic action of vertical tools (blades) placed on the rotors, driven - through a gears transmission - from the tractor PTO by means of the cardan shaft connection. Each rotor is composed of two blades, with opposite rotation compared to the contiguous rotors. The cardan shaft is equipped with a safety device to preserve the machine's transmission from excessive overloads.

The machine allows a very good job of seedbed leveling and finishing, with rich production of fine soil homogeneously distributed on the ground surface, and is used at best in operations on tough soils, not subjected to excessive action of the atmospheric conditions (for example, for the preparation in autumn-winter season of a cereal's seedbed, following to a summer crop).

The power harrow is equipped with a leveling bar and a rear roller.

The leveling bar, together with the side plates, allows retaining the thickest clods in the working area of the rotors, improving the soil refining, and generating a first leveling action before the action of the roller.

The rear roller, supported by a frame linked to the side plates of the machine by means of two swinging arms, allows the working depth control and the soil leveling. Depending on the characteristics of the soil and the desired result, the following types of roller can be used:

- **Cage roller:** is suitable for dry soils or with medium-low degree of humidity. It allows controlling the working depth, leveling the worked soil, and completing the refinement of the seedbed.
- **Spike roller:** is suitable for each type and condition of soil, in particular for soils with high degree of humidity. It does not compact the soil, but leaves it leveled and ventilated, providing excellent drainage. It is mainly used when is required a preparatory work of the soil already deeply worked.
- **Packer roller:** is suitable for any type and condition of soil. It is recommended for heavy soils and for soil preparation in combination with a seed drill. Allows refining the surface of the seedbed, and has a great effect leveling and crumbling on the surface and in depth.

The machine is designed to be mounted on medium-high power tractors equipped with hydraulic lift and universal three-point hitch that can support the implement weight, and is driven by the power of the tractor through the PTO drive shaft.

The tractors used to operate the machines must have the following requirements:

Hitch Category:	3-point, Category 2 (ISO 730 standard)
PTO:	540 RPM
Horsepower:	from 50 to 80 HP



DANGER

Any use of the machine other than the intended use is non-intended use, and is to be considered as unauthorized and dangerous. The manufacturer assumes no liability for damage resulting from non-intended use.

LIGHT POWER HARROW

2.3. MAIN PARTS DESCRIPTION

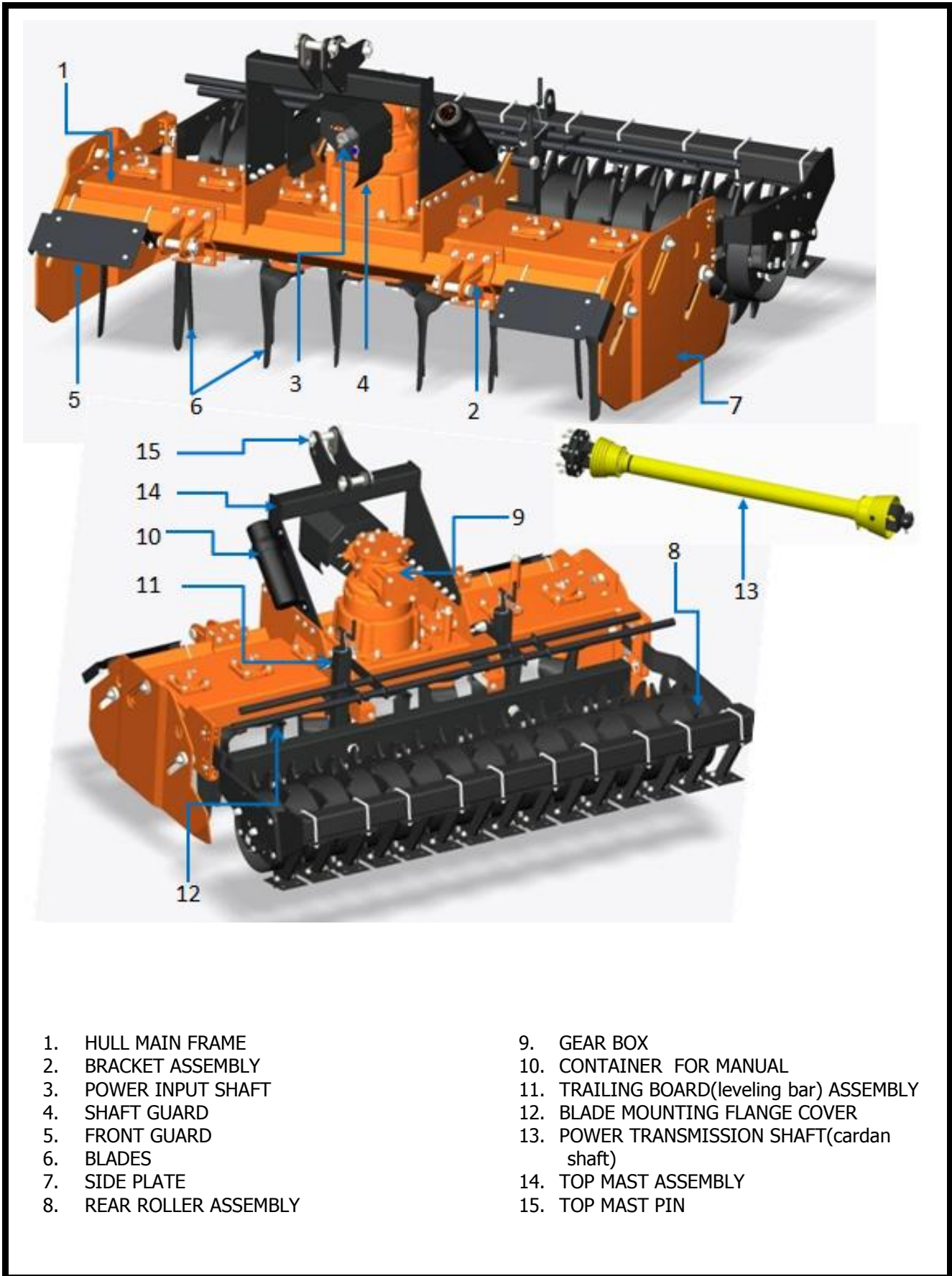

LIGHT POWER HARROW







2.4. REAR ROLLERS

	<p>Packer Roller (Ø450)</p>
	<p>Spike Roller (Ø490)</p>
	<p>Cage Roller (Ø400)</p>
<p>16. PACKER ROLLER PIPE 17. PACKER ROLLER SCRAP PIPE 18. ROLLER MOUNTING PLATE RH 19. ROLLER MOUNTING PLATE LH 20. SCRAPPER MOUNTING PLATE 21. PACKER RING</p>	<p>22. SPIKE ROLLER C-CHANNEL 23. ROLLER SQ.PIPE 24. SPIKE 25. SPIKE ROLLER ROUND PIPE 26. CAGE ROLLER MID PLATE 27. CAGE ROLLER ROUND PIPE</p>

NOTE To make the illustrations more clear, some images of this manual may refer to the machine lacking of some components (e.g. safety devices and barriers).

LIGHT POWER HARROW

2.5. TECHNICAL SPECIFICATIONS

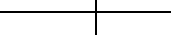
Model		Working Width	Working Depth				Overall Dimensions (L x W x H)
	Total Width cm	cm / Inch	cm /Inch	HP	BLADS	Kg	
SRP-125		125 / 49.2	10-20 / 4-8	50 - 65	10	390 / 860	150 x 136 x 110
SRP-150		150 / 59.1	10-20 / 4-8	55 - 70	12	430 / 948	150 x 161 x 110
SRP-175		175 / 68.9	10-20 / 4-8	60 - 75	14	470 / 1036	150 x 185 x 110
SRP-200		200 / 78.7	10-20 / 4-8	65 - 80	16	510 / 1124	150 x 210 x 110

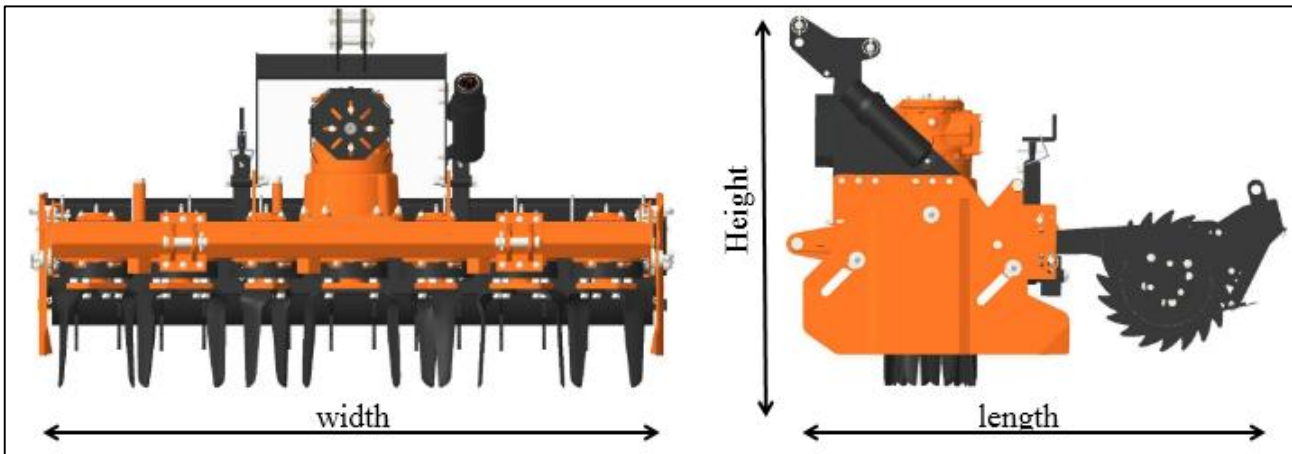

PACKER ROLLER	OVERALL DIMENSION(LxWxH)	DIAMETER(mm)	WIEGHT(Kg)
SRP-125	830x1366x540	420.00	139.00
SRP-150	830x1611x540	420.00	158.00
SRP-175	830x1856x540	420.00	177.00
SRP-200	830x2101x540	420.00	196.00

SPIKE ROLLER	OVERALL DIMENSION(LxWxH)	DIAMETER(mm)	WIEGHT(Kg)
SRP-125	830x1366x540	504.00	106.00
SRP-150	830x1611x540	504.00	121.00
SRP-175	830x1856x540	504.00	136.00
SRP-200	830x2101x540	504.00	151.00

LIGHT POWER HARROW

CAGE ROLLER	OVERALL DIMENSION(LxWxH)	DIAMETER(mm)	WIEGHT(Kg)
SRP-125	740x1366x370	383.00	68.00
SRP-150	740x1611x370	383.00	76.00
SRP-175	740x1856x370	383.00	84.00
SRP-200	740x2101x370	383.00	92.00

3.SAFETY

Proper use of the equipment, a strict observance of the safety messages listed below and application of all reasonable practices to avoid any risks, prevents accidents or injury, allows the machine working better and longer, and minimize the failures.

The manufacturer assumes no liability for any damage resulting from not applying the behavioral rules indicated into the manual.

3.1. GENERAL SAFETY INSTRUCTION



DANGER

The machine must be used only by authorized and well trained operators. The operator must have read and understood the instructions of this manual, it must make adequate preparation for the proper use of the machine and must hold a driving license. In case of doubt about the use of the machine and/or the interpretation of this manual, the operator must contact the Manufacturer or the Dealer.



WARNING

The manual must always remain with the machine. In case of loss or damage, request a new copy to the Manufacturer or your Dealer.



WARNING

Follow strictly the rules prescribed by the safety pictograms applied to the machine.



WARNING

Be sure that all safety pictograms are legible. If pictograms are worn, they must be replaced with others obtained from the Manufacturer, and placed in the position indicated by this manual.



DANGER

Before using the machine, make sure that all safety devices are installed and in good working conditions. In case of damages of shields, replace them immediately.



DANGER

Is absolutely forbidden to remove or alter safety devices.



DANGER

Before starting, and during operation of the machine, make sure there are no people or animals in the operation area: the machine can project material, with risks of serious injury or death.



PERICOLO

Do not leave the tractor engine running where in enclosed areas and without a system ventilation capable to dispose the harmful exhaust gases produced in the air.



DANGER

Pay maximum attention to avoid any accidental contact with rotating parts of the machine.



DANGER

During operation, adjustment, maintenance, repairing or transportation of the machine, the operator must always use appropriate Personal Protective Equipment (PPE).



DANGER

Do not operate the implement while wearing loose fitting clothing that can give rise to entanglement in parts of the machine.



DANGER

Do not operate the implement when tired, not in good condition or under the influence of alcohol or drugs.



CAUTION

If the use of the machine is required at night or in conditions of reduced visibility, use the lighting system of the tractor and possibly an auxiliary lighting system.

3.2. EQUIPMENT SAFETY INSTRUCTIONS



WARNING

Use the machine for its intended purpose only. Improper use can damage the machine and cause serious injury to persons, animals, or death.



DANGER

The machine should be used by a single operator driving the tractor.



WARNING

Any unauthorized modification of the machine may cause problems in safety and relieves the Manufacturer from any liability for damages or injuries that may result to operators, third parties and objects.



WARNING

Before using the machine, familiarize yourself with its controls and its working capacity.



WARNING

Do not leave the machine unattended with tractor engine running.



WARNING

Do not operate the machine on too muddy, sandy or rocky soils.



WARNING

Keep the machine clean from debris and foreign objects which may damage functioning or cause injury.



WARNING

Do not use the machine if the category of the connecting pins does not match that of the tractor hitch system.



WARNING

Do not use the machine with missing bolts, screws, pins or safety pins.



WARNING

Never use the machine to transport or lift people, animals or objects.



WARNING

Make certain, by adding front ballast, that at least 20% of the total weight (tractor, implement and ballast) is on the front axle of the tractor, to ensure stability.



WARNING

Before engaging the tractor PTO, make sure the tractor PTO speed is set as required for the machine (540 or 1000 rpm). Do not over speed PTO or machine breakage may result.



DANGER

Do not operate the machine if the driveshaft is damaged. The driveshaft could be subjected to breakage during operation, causing serious injury or death. Remove the driveshaft and replace it with an undamaged.



DANGER

When the machine is disconnected from the tractor, rest the driveline on the provided support.

3.3. OPERATING SAFETY INSTRUCTION



WARNING

Before using the machine, be sure to have cleared the operating area from obstacles (stones, branches, debris, etc...). Mark all the obstacles that cannot be eliminated (e.g. by means flags).



DANGER

Never engage the tractor PTO in the presence of people close to the driveshaft. The body, hair or clothing of a person can get caught in rotating parts, causing serious injury or death.



DANGER

Before engaging the PTO and during all operations, make sure that no person or animal is in immediate area of action of the machine. Never use the machine if people are in his working area.

 **DANGER**

It's absolutely forbidden to stand near the machine with moving parts.

 **WARNING**

The operator must operate machine lifting/lowering only from the driving seat of the tractor. Do not perform lifting maneuvers on side or behind the tractor.

 **WARNING**

Before making changes in direction, turns or going in reverse, slightly lift the machine from the ground after disengaged the power take-off, to prevent damages to the machine.

 **DANGER**

In presence of steep slopes (greater than 15 degrees) the action of the machine may cause instability of the tractor, with risk of tipping and consequent serious injury or death hazard. Consult the manual for the tractor to determine the maximum slope that the tractor is able to deal with.

 **DANGER**

Always disengage the PTO before raising the machine, and never engage the PTO with the machine in raised position. The machine might throw objects at high speed, causing serious injury or death.

 **WARNING**

Never leave the driver's seat when the tractor is turned on. Before leaving the tractor, lower the machine to the ground, disengage the PTO, insert the parking brake, stop engine and remove the key from the control panel.

 **DANGER**

The PTO shields of tractor and implement sides, the driveshaft shielding and the driveshaft retaining chains must be properly installed and in good condition, to avoid risk of entanglement with serious injury or death.

 **DANGER**

Before engaging the PTO of the tractor, always make sure that the drive shaft is mounted in the correct direction, and that its clamping elements are properly connected both to tractor side and to implement side.

 **WARNING**

Stop operating immediately if blades strike a foreign object. Repair all damage and make certain that rotor and blades are in good condition before resuming operation.

 **WARNING**

Always disengage the tractor PTO when the driveshaft exceed an angle of 10 degrees up or down while operating. An excessive angle with driveshaft rotating can break the driveshaft and cause flying projectiles.



CAUTION

Avoid clutch's overheating caused by too long or frequent slipping of the clutch, since it can damage the clutch components. Before checking slip clutch, make sure it has cooled. Clutch could be extremely hot and cause severe burn.



CAUTION

Prolonged use of the machine can cause overheating of the gearbox. Do not touch the gearbox during use and immediately after, it could be extremely hot and cause severe burn.



WARNING

All adjustment operations on the machine must be performed by qualified and trained operators, with the tractor engine off, the PTO disengaged, the machine lowered to the ground or on security stands, the ignition key off and the parking brake set.

3.4. TRANSPORTING SAFETY INSTRUCTIONS



WARNING

Before transporting, determine the stopping characteristics of the tractor-implement assembly.



WARNING

Transport only at speeds where you can maintain control of the equipment.



WARNING

When driving on roads, the machine must be in transport position adequately raised from the road surface, with tractor lifting hydraulics locked so that the machine cannot be lowered accidentally.



DANGER

The implement may be wider than the tractor. Pay attention during transporting to persons, animals or obstacles exposed.



WARNING

When turning, use extreme care and reduce tractor speed.



WARNING

Do not operate the tractor with weak or faulty brakes or worn tires.



CAUTION

Always use tractor lighting system and auxiliary lighting system for adequate warning to operators of other vehicles, especially when transporting at night or in conditions of reduced visibility.



DANGER

In case of machine lifting, make sure that the lifting device chosen is suitable to perform the operation safely, and use only the lifting points prescribed for the machine.

3.5. MAINTENANCE SAFETY INSTRUCTION



WARNING

All maintenance and repairing operations must be performed by qualified and trained operators, with the tractor engine off, the PTO disengaged, the machine lowered to the ground or on security stands, the ignition key off and the parking brake set.



WARNING

Perform repairs and replacements necessary to the machine using only original spare parts provided by the manufacturer or your Dealer.



DANGER

Perform maintenance operations always using appropriate Personal Protective Equipment (protective eye glasses, hard hat, hearing protection, safety shoes, overall and work gloves, filter mask).



PERICOLO

During any cleaning and maintenance operations, make sure That there is adequate ventilation to prevent accumulations of toxic vapors in the air.



CAUTION

Before any maintenance operation, make sure that the parts which may become hot during use (friction clutch, gear box...) have cooled.



WARNING

Do not perform repairs that you do not know. Always follow the manual instructions and in case of doubt contact the Manufacturer or your Dealer.



DANGER

Do not swallow fuels or lubricants. In case of accidental contact with eyes, rinse well with water and consult a doctor.



PERICOLO

Always keep oils and lubricants out from children.

3.6. STORAGE SAFETY INSTRUCTIONS



WARNING

Never leave the tractor unattended with the machine in lifted position. Accidental operation of lifting lever or a hydraulic failure may cause sudden drop of unit with injury or death by crushing.



DANGER

Following operation, or before unhooking the machine, stop the tractor, set the brakes, disengage the PTO, lower the attached machine to the ground, shut off the engine, remove the ignition key and wait for all moving parts to stop.



WARNING

Make sure all parked machines are on a hard, level surface and engage all safety devices.



CAUTION

Place support blocks under the machine as needed to prevent unit from tipping over onto a child and/or an adult. A machine that tips over can result in injury or death.



CAUTION

Store the unit in an area away from human activity.

3.7. SAFETY LABELS

The safety labels applied on the machine give fundamental information for using the machine safely.



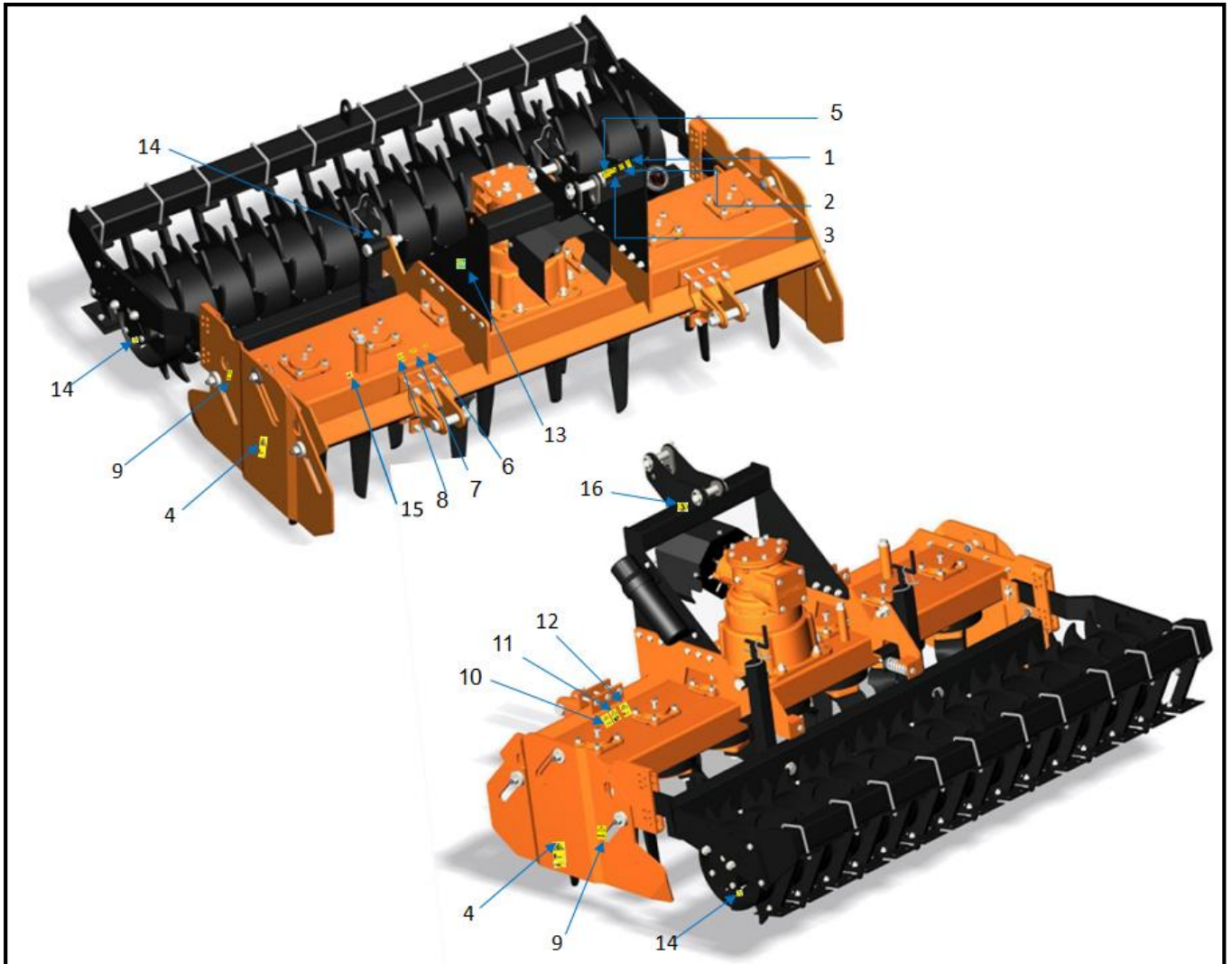

Make sure safety labels are in good conditions. If pictograms are worn, they must be replaced with others obtained from the Manufacturer and placed in the position indicated by this manual.

Make sure the safety labels are legible. If necessary, wipe them by a cloth, with soap and water.







SAFETY LABELS POSITION AND DESCRIPTIONS







LIGHT POWER HARROW

1		<p>Carefully read the operator's manuals of the machine, Tractor and cardan shaft before using the machine.</p>
2		<p>Disengage the PTO, turn off the tractor engine, remove the key and ensure that all rotating parts have Stopped before approaching the implement. Read the operator's manual before performing any maintenance operation.</p>
3		<p>Thrown or flying objects hazard. Keep a safe distance from the machine.</p>
4		<p>Rotating knives: severing of lower limbs hazard. Keep a safe distance from the machine.</p>
5		<p>Cutting of fingers or hand hazard. Wait until all machine components have Completely stopped before touching them.</p>

LIGHT POWER HARROW

6		<p>Crushing hazard. Stay clear of draft link lifting range while in operation.</p>
7		<p>Implement input driveline: Body entanglement hazard. Do not open or remove safety shields while engine is running.</p>
8		<p>Before engaging the tractor PTO, check that rpm rate and sense of rotation are those prescribed for the implement.</p>
9		<p>Upper limbs crushing hazard. Keep hands at safe distance from the machine.</p>
10		<p>Danger of burning. Hot surface. Before touching the gearbox surface, Wait until it has cooled.</p>
11		<p>Risk of falling. It is forbidden to ride on the implement or climb The implement when running.</p>

LIGHT POWER HARROW

12		<p>Skin injection hazard. Relieve pressure before disconnecting hydraulic lines And tighten all connections before applying pressure. Read the manual for maintenance procedures.</p>
13		<p>Always wear protective clothing and equipment appropriate for the job: hearing protection, safety shoes, safety gloves, safety glasses and overall.</p>
14		<p>Lubrication point (oil).</p>
15		<p>Lubrication point (grease).</p>
16		<p>Lifting point.</p>

4.SET-UP

The machine is delivered equipped with a driveshaft with torque limiter (clutch discs) and related operating manual.

When the machine is delivered, check that there is no damage to the machine or driveshaft. In case of damage or missing parts immediately notify the Manufacturer or your Dealer.

Because of his size, the machine could be delivered with some parts disassembled (for instance, the EC safety guards).

In this case, the assembly of such parts is an owner's task, and must be performed carefully, with reference to the breakdown tables of the Spare parts section, applying the correct tightening of screws and bolts. In case of doubt immediately contact the Manufacturer or your Dealer.

ATTENTION

For proper tightening torques of bolts and screws, refer to the table of this manual.

4.1 HANDLING

To perform machine lifting and/or handling, operators must use a lifting device (e.g.: crane) with suitable load capacity, equipped with accessories (belts, chains...) in good condition. The machine must be hooked at the appropriate lifting points indicated by pictograms (see Paragraph "Safety labels").

To make sure that the load capacity of the lifting device is correct, check the weight of the machine under "Specifications" of this manual.

Before performing any operation the operator must:

- make sure there are no people or animals in the operation area;
- clear and delimit the handling area, making sure that there is an escape space in case of falling of the load;
- check the load capacity of the lifting device.

During handling:

- do not touch suspended loads and remain at a safe distance;
- Unless special needs, avoid lifting the loads to more than 20 cm from the ground.

The transportation of the machine disconnected from the tractor is possible using a truck with suitable power and size, selected in accordance with the machine weight and dimensions given in the paragraph "Specifications" of this manual. The truck shall be equipped with a loading bed, in order to avoid movements during the transportation.

After performing the lifting and the positioning of the machine over the truck, firmly secure the machine to the loading bed by means of ropes or chains pulled taut to the anchor points provided.

After transportation, verify that the position of the machine do not represent a danger. Remove the ropes or chains and proceed with unloading, following the same attention used during loading.



DANGER

Lifting and transportation operations can be very dangerous and must be done paying the maximum attention, by authorized and trained operators, equipped with appropriate Personal Protective Equipment (PPE).

4.2 BARCKET PINS(LOWER HITCHES) CHECK

The power harrows are designed to be mounted on tractors equipped with **3-point PINS (hitch) Category 2 (ISO 730 standard)**.

Before connecting the machine to the tractor:

- Make sure that the machine is equipped with lower brackets having Category 2 pins (D=28 mm). The brackets must be oriented into their slots as showed in below picture.
- Make sure that the machine is equipped with Category 2 upper pin (D=25.5 mm), positioned on the hole of the top mast plate as a shown in below picture.

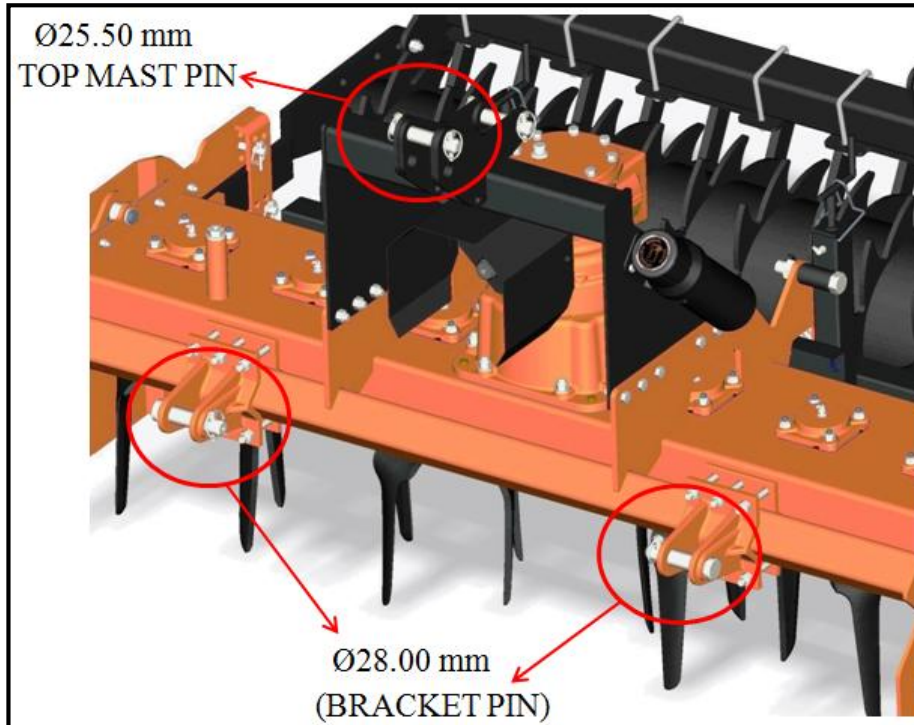

If the dimension of the pins is not corresponding to Category 2, contact the Manufacturer or the Dealer to obtain the pins of right dimension.

4.3 CONNECTING TO THE TRACTOR

⚠ WARNING

Before connecting the machine to the tractor, make sure that tractor and machine are on a flat, stable and dry surface.

To connect the machine to the tractor the operator must do the following:

- drive the tractor in reverse up to the machine placed in parked position, then align the hydraulic lifting arms to the machine's bracket pins (see the picture below);

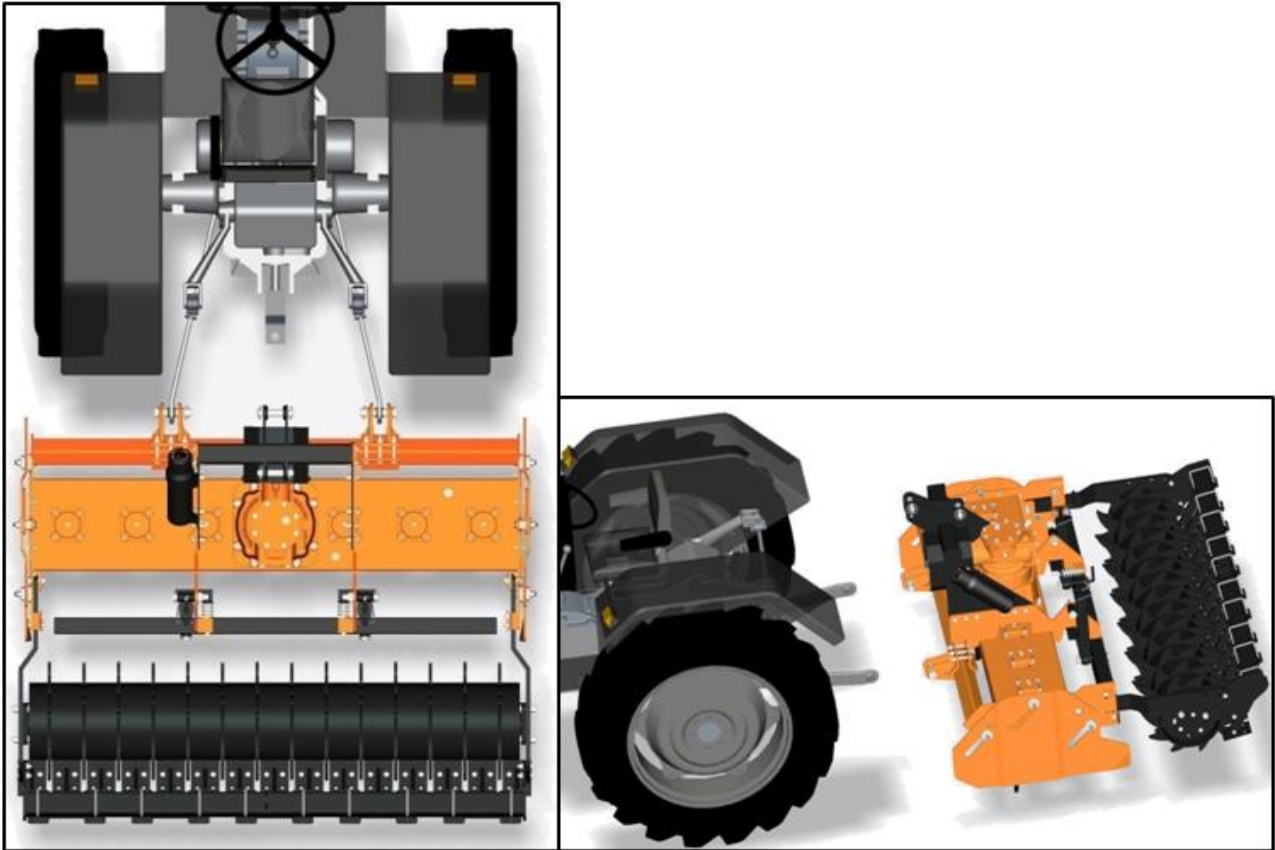

- set the tractor's parking brake, stop engine, remove the ignition key and get off the tractor;
- connect the lifting arms of the tractor to the lower bracket of the machine, through the use of the pins and the related safety split pins;
- connect the tractor top link to the machine top link plate through the use of the pin and relative safety split pin;
- raise the machine until PTOs of tractor and machine are at the same height, then adjust the tractor top link so that the front of the machine is leveled to the back (the axis of the machine input connection shaft must be parallel to the ground), in order to limit stress transmitted to the machine through the cardan shaft;
- make sure that left side of the machine is leveled with the right, by adjusting the tractor lifting arms, then lock the arms to prevent swinging that could compromise the stability of tractor and machine;
- Proceed with the driveline connection (see Section Driveline installation).

4.4 DRIVELINE INSTALLATION

The machine is equipped with a cardan driveshaft (transmission shaft) with torque limiter (friction discs clutch or automatic cam clutch) that preserves the machine from overloads.

Before installing the driveshaft, the operator must read the manuals of driveshaft and tractor, checking in particular that rpm and direction of rotation of the tractor PTO match those of the machine (540 rpm).

If the direction of rotation of the tractor PTO does not match that of the machine, contact the Manufacturer or your Dealer.

To connect the driveshaft to the tractor and implement, the operator must:

- park tractor and machine on a flat surface, with parking brake set, engine off, and ignition key removed;
- check that safety devices of driveshaft, machine and tractor are in good condition, otherwise provide for their replacement;
- remove the PTO shield of the machine through the fixing screws;
- position the driveshaft with clutch turned towards the implement side;
- insert the clutch hub on the input connection shaft of the machine, then ensure its tightening onto shaft through its fastener;
- replace the PTO shield of the machine through the fixing screws;
- insert the driveshaft yoke on the tractor PTO, then ensure its tightening onto shaft through its fastener;
- Hook to the tractor and machine the two retaining chains of the driveline shielding, to prevent shielding rotation during functioning of the machine.

DRIVELINE LENGTH CHECK

Before operating the machine, ensure that the size of the driveshaft is adequate. The driveshaft supplied with the machine has a standard length; therefore it may need an adaptation of the length, depending of the tractor which the machine is combined.

The length of the driveshaft must be such to:

- avoid bottom out of the transmission tubes, when the driveshaft is in compressed position (when machine is raised up off the ground);
- Ensure an overlapping of the transmission tubes enough to transmit the torque required, when the driveshaft is in max extension (when the machine is in its lowest position in the ground).

When the driveshaft is at its minimum length (max compressed position), there must be at least a 2 cm of distance between the ends of each transmission tube and the yokes side.

When the driveshaft is at its maximum operational extension, there must be an overlap between the tubes profiles of 15 cm at least.

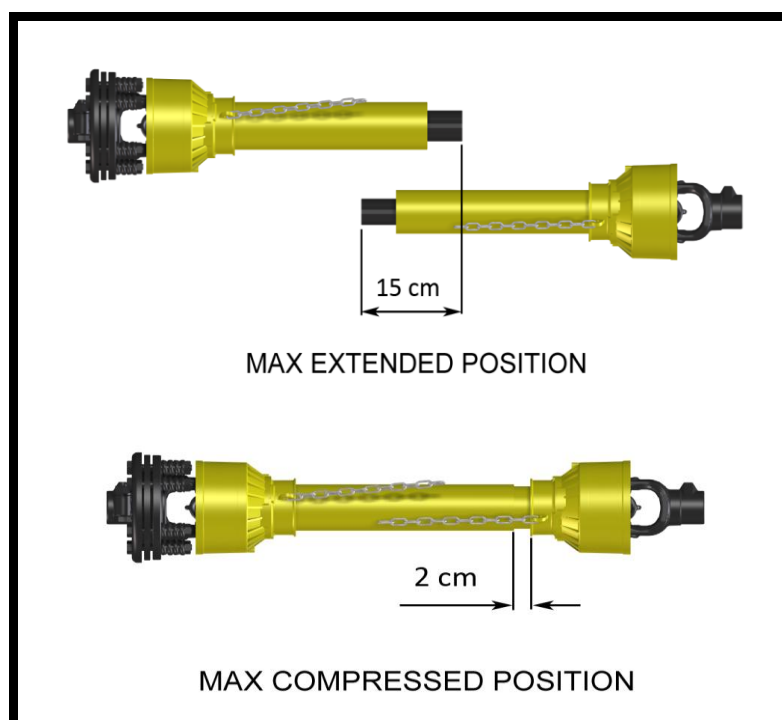

A driveshaft too long may cause structural damages to the tractor and machine. If the driveshaft is too long, it may be adapted by removing it and shortening the tubes according to the instructions provided by the Manufacturer in its use and maintenance manual.

A driveshaft too short can cause disengage of the tubes during operation, with severe hazard for the operator and structural damage to the tractor and machine. If the driveshaft is too short, it must be replaced with a longer one. In this case contact the Manufacturer or your Dealer.

IMPORTANT

- Before operating the machine the first time, make sure that the driveshaft is lubricated in accordance with how indicated in the instruction booklet.
- if the torque limiter provided with the cardan shaft is a friction discs clutch, before operating the machine the first time, and after long periods of inactivity, make sure that the driveline clutch has run a short "run in" in accordance with what indicated in the instruction manual of the

LIGHT POWER HARROW

Manufacturer, removing the possible oxidation of the components that may compromise the correct slipping during the usage (see also section "Maintenance")

- Always engage the tractor PTO at low rpm to minimize the effect of the peak torque on the driveline and the machine.

4.5 HYDRAULIC CONNECTION

If the machine is equipped with a rear roller with hydraulic cylinders, it is necessary to connect the machine's hydraulics to the tractor to allow the appropriate adjustments of the roller (lifting and lowering).

To make the connection the operator must press vigorously the hydraulic hoses with quick coupling into the corresponding seats of the tractor, until the connection is done (see picture).

Sticking labels are placed next to the quick couplings of the hydraulic pipes to identify the lifting hose and the lowering hose of the roller.

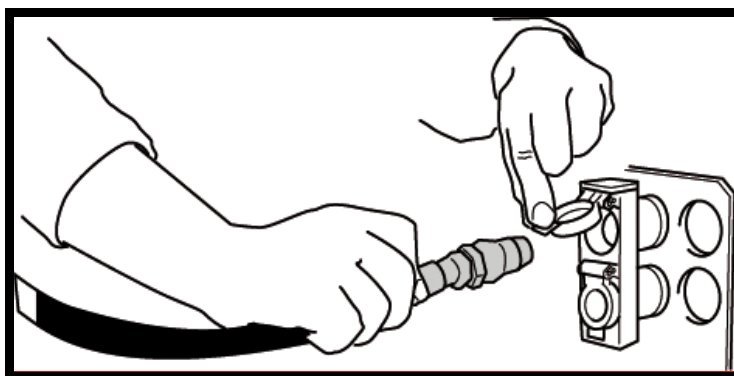

WARNING

Check the hydraulic pipes frequently and replace them whenever they show signs of wear or if small cracks form in the rubber.



DANGER

Before carrying out operations on hydraulic lines under pressure or disconnecting hydraulic components, ensure the line has been previously depressurized and does not contain any hot fluid.

CONNECTION OF ADDITIONAL IMPLEMENTS

The power harrow can be combined with other implements that complete his work, like fertilizers spreaders or seeders.

LIGHT POWER HARROW

In this case, to allow the connection of the above implements to the power harrow is required a dedicated support frame provided by the Manufacturer or by the Dealer (not included in the standard harrow supplied), and the operator must perform the following operations:

- connecting the support frame to the power harrow;

Always refer to the Operators Manuals of the implements to perform correctly the above operations.

Check the compatibility of the tractor's performance with the weight transferred by the machine and additional implements to the tractor 3-point hitch. In case of doubt, contact the tractor manufacturer.

The maximum working speed of the tractor when the machine is equipped with additional implements must not exceed 3 km/h in order to avoid breakage or damages.



WARNING

If additional implements are used combined to the machine, keep much attention to the risks that may be generated during the phases of connection, use and disconnection of the implements.

All maintenance and repairing operations must be performed by qualified and trained operators, with the tractor engine off, the PTO disengaged, the machine lowered to the ground or on security stands, the ignition key off and the parking brake set.

4.6 TRACTOR-MACHINE STABILITY

Connecting the machine to the tractor implies a change of loads distribution on the tractor axles.

LIGHT POWER HARROW

Before connecting the machine to the tractor it is required to check the stability of the tractor-machine system, in order to determine the ballast to apply to the front of the tractor, and assure adequate distribution of the weight on the axles.

In order to assure the stability it is necessary that the following relations are verified (see table below for definitions):

$$1) M \times (S1+S2) \leq 0.2 \times T \times i + Z \times (d+i)$$

$$2) M \leq 0.3T$$

Consequently, the minimum ballast required is:

$$Z \text{ min} = (M \times (S1+S2) - 0.2 \times T \times i)/(d+i).$$

To determine the appropriate characteristics of the ballast, refer to the manual of the tractor.

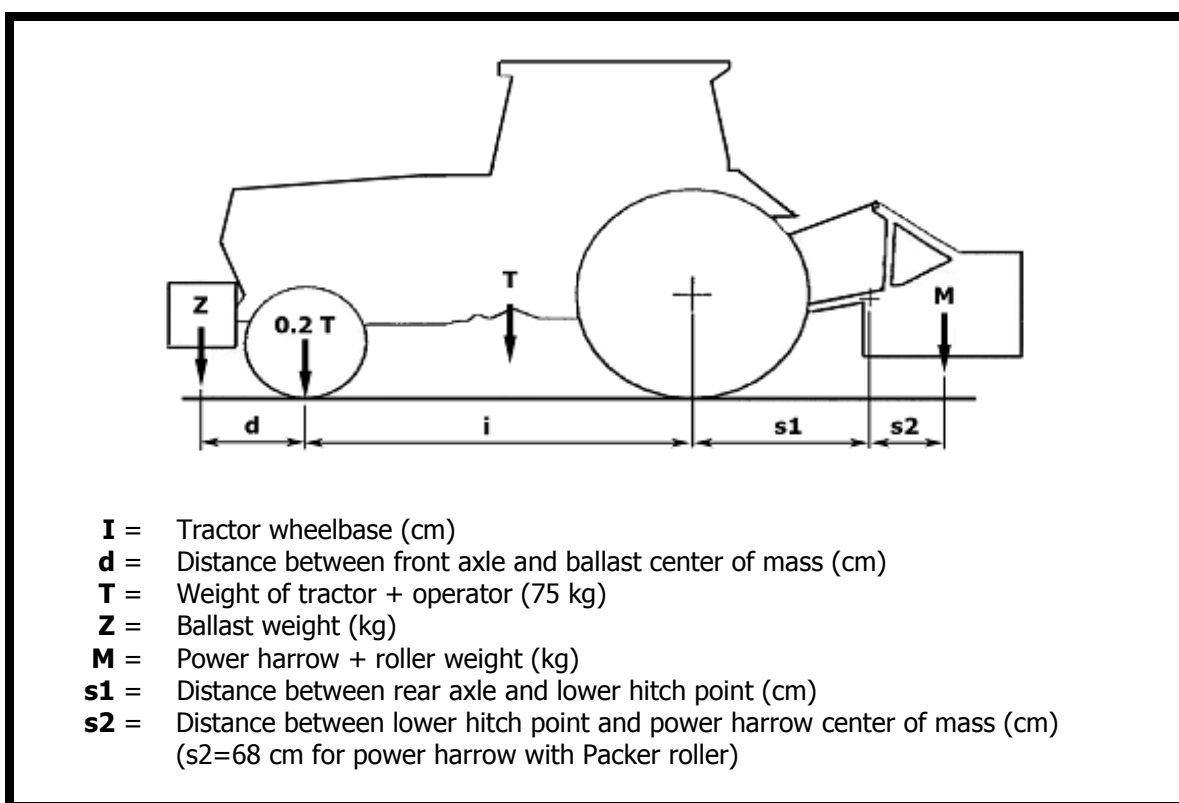

If the machine is combined with other machines (fertilizers spreaders or seeders), the ballast check must be done considering:

M = total weight of the implements (power harrow+roller+spreader/seedler),

S2 = Distance between lower hitch points and center of mass of implements
(power harrow+roller+spreader/seedler).



CAUTION

The weight of the machine modifies the stability of the system tractor-machine, resulting in loss of steering control and braking.

4.7 TRANSPORT

To set the machine for transportation, when connected to the tractor, perform the following steps:

LIGHT POWER HARROW

- idle tractor engine, disengage tractor PTO, and wait for stopping of all rotating parts;
- lock the tractor lifting hydraulics, turn off the engine, set the parking brake, remove ignition key and get off the tractor;
- be sure that the tractor's lifting arms are locked horizontally, to prevent the machine from swinging, compromising the stability of the tractor and the machine;
- Check the lifting capacity and stability of the tractor connected to the machine in transport position (see section "Tractor-machine stability"), and apply to the tractor a ballast of at least 20% of tractor and implement weight. Without ballast, the front wheels of the tractor could lift up, resulting in loss of steering control and braking. Ballast can be added to the front wheels or to the front of the tractor;
- lift the machine until the transport position (approx 35-40 cm from the ground), making sure the driveline transmission tubes does not hit either the tractor or the machine gearbox. A minimum gap of 2 cm should be leaved between the tubes and tractor and machine (see also section Driveline installation).



CAUTION

Make sure PTO is disengaged and blades have stopped turning before raising the machine to transport position.



WARNING

Never leave the tractor unattended with the implement in the lifted position.

During transportation:

- Always use caution and select a safe ground speed appropriate for the terrain. Reduce speed when under adverse surface conditions, turning, or on inclines. Take care that the implement does not strike obstacles such as trees, fences or buildings;
- Do not operate PTO. Always transport the implement with disengaged PTO;
- do not transport on steep slopes;
- do not transport equipment while under the influence of alcohol or drugs;
- do not use the machine to transport people, animals or things;

During transportation on public roads:

- install all the warning devices required by current regulations for transit (rear reflectors, lighting systems, flashing, Slow Moving Vehicle signal and/or Protruding Moving Vehicle signal);
- Always comply strictly with all federal, state and local laws and traffic regulations.



WARNING

When driving on public roads, reduce your speed, be aware of traffic around you and proceed in such a way that faster moving vehicles may pass you safely.

Always use tractor lighting system and auxiliary lighting system for adequate warning to operators of other vehicles, especially when transporting at night or in conditions of reduced visibility.

5. OPERATING

Before operate the machine, make sure you have read and understood the operating manuals of the machine, tractor and PTO shaft, and followed what is described in the section "Set Up".



DANGER

During operation, adjustment, maintenance, repairing or transportation of the machine, the operator must always use appropriate Personal Protective Equipment (PPE).

Before starting work, ensure that tractor, implement and driveline's safety guards are in good conditions and fully functional.

During operation, the machine can throw material from the back: prevent people and animals to approach the operational area.

5.1. START UP AND REUSING

Before the start up and before reusing the machine after long term storage (e.g. after seasonal end), perform the following **pre-operational inspections and service of the implement**, to assure that the machine is in perfect condition and ready to be used:

- Check that the machine has not damaged functional parts and has all mechanical parts in good condition. Repair and / or replace the damaged parts.
- Check that the machine has no missing parts (pins, safety pins, plugs oil ...). Restore the missing parts.
- Check that all guards and safety devices have no damages and are properly positioned. Repair and / or replace the damaged shielding, restore the correct position.
- Verify that the PTO driveshaft is properly installed (see section: Driveline installation).
- Check that the torque limiter provided with the cardan shaft is in good condition, and, in case is a friction discs clutch, that its components are not subject to "sticking" (see section Driveshaft maintenance).
- Check for oil leaks from the gearbox or the transmission side cover. Identify the reason of loss, then repair and / or replace the damaged components.
- Check the presence of lubricant in all greasing points of the machine (driveshaft, supports...) (see section Maintenance).
- Check the correct oil level in the gearbox and in the gears trough (see section Maintenance).
- Check for oil leaks from the gearbox, the gears trough, hydraulic tubes. Identify the reason of loss, then repair and / or replace the damaged components.
- Check that blades are not excessively worn and the relating hardware is correctly tightened (see section Maintenance).
- Check that all the hardware is properly tightened. Refer to the tightening table in the manual for proper torque values.
- Check that all safety decals are correctly positioned, in good condition and legible. Replace any damaged decals.
- Check that there is no constraint that may prevent the movement of the machine. Remove any constraint.
- Check the tractor, to ensure correct direction of PTO and rpm speed.

LIGHT POWER HARROW

Before the start up and before each use, make the following checks on the area identified for operating the machine:

- Check that area is clear of foreign objects (rocks, branches or debris). Remove any obstacle and visibly highlight obstacles that cannot be eliminated (e.g. by means flags).
- Make sure in the working area exposed there are no people or animals.
- Make sure the soil to be worked is not too grassy, muddy, sandy or rocky.



WARNING

Before conducting the above inspections and service, make sure the tractor engine is off, all rotation parts are completely stopped and the tractor is in park with the parking brake engaged. Make sure the machine is resting on the ground or securely blocked up and the tractor lifting hydraulics locked.

Once all the checks above have been done, start tractor and machine as follows:

- start engine tractor and engage the tractor PTO at low rpm, making sure that the machine is NOT in the raised position but close to the ground, then increase speed engine until to 540 rpm or 1000 rpm, according to the tractor model and the gears set into the gearbox (see section "Gearbox speed adjustment").
- Lower the machine on the ground and simultaneously start driving the tractor at low speed. Subsequently increase the ground speed until the desired speed is obtained, depending on ground conditions.
- If the environmental temperature is very cold, it's recommended to wait a few minutes with the PTO of the tractor at low rate before completely lowering the machine on the ground.
- Drive for a while operating the machine, then stop the tractor to check the quality of the work performed and if the machine is adjusted properly.

If the working depth and/or soil texture are not as desired, correct them performing the necessary adjustments that can be performed on the machine (see sections "Adjustments"), then start operating again following instruction described into the section "Operating Instructions".



WARNING

If you need to get off the tractor, lift the machine just out of the ground, reduce engine speed and disengage PTO, set the parking brake, stop engine and remove the ignition key.

5.2. OPERATING INSTRUCTIONS

Drive the tractor adjusting the ground speed according to the desired grade of soil refining. A low ground speed allows a better crumbling effect and a high grade of soil refining, while a high ground speed allows a reduced crumbling effect and a lower grade of soil refining.

In addition to the tractor ground speed, the factors influencing the grade of soil refining are the following:

- nature of the soil (medium texture, sandy, clayey etc.) and soil humidity;
- working depth;
- blades rotation speed;
- levelling bar height.

High blades speed gives high crumbling capacity and soil refining and vice-versa. The machine is equipped with a central gearbox with speed change that allows changing the blades speed (see

LIGHT POWER HARROW

"Gearbox speed adjustment") according to different working conditions (nature of the soil, soil humidity content, ground tractor speed etc.).

ATTENTION

The higher the blades speed, the greater the grade of soil refining, but also the power absorbed by the tractor, as well the greater the wear of the tools. In most cases it is suggested, therefore, the use of the lower rotation speed.

During operations:

- Always keep the tractor ground speed adequate to conditions of the soil to be worked (from 2 to 8 km/h approx.). Reduce speed in the case of hard or stony soils.
- Always keep the tractor engine at rpm rate ensuring to the machine the right power required for the use.
- Choose a driving pattern that provides the maximum pass length and minimizes turning.
- When working on hills, do "climbing" in the sense of the slope if possible, in any case do not work along the hillsides, and make the steps from top to bottom to reduce terracing effect.
- Always perform changes and reverse of direction with PTO disengaged and the machine slightly lifted from the ground to avoid damage to the machine.
- Do not allow the machine to drop heavily on the ground, but lower it slowly leaving the blades gradually penetrating the soil, in order to limit mechanical stresses on machine components, and preserving its integrity.
- Do not operate the machine loosely out of the soil. Never work in reverse.
- Periodically check for foreign objects wrapped around the blades, rotor shafts and roller. Remove them, after disengaging PTO, turning off tractor engine, and removing ignition key.
- If the blades strike a foreign object, or in case of prolonged intervention of the clutch due to an object wedged into the rotors, stop operating immediately, idle the engine speed and disengage the PTO. Wait for stopping of all rotating parts, then raise the implement and proceed to removing the object, after stopped the tractor, set the parking brake, stopped engine and removed the ignition key. Repair any damages immediately, and make sure rotor and blades are in good condition before restarting operation.
- Always disengage the tractor PTO when the driveshaft exceed an angle of 10 degrees up or down between end yokes while operating. An excessive angle with driveshaft rotating can break the driveshaft and cause flying projectiles.
- Avoid friction clutch overheating caused by too long or too frequent slipping of the clutch (friction discs clutch or cam-type clutch), since this can damage the friction plates and/or clutch parts. In case of functioning problem, do not open the clutch but contact the Manufacturer or a service center.

Some of typical problems that may occur when operating the machine are described into Troubleshooting section, together with their possible solutions.

5.3. ADJUSTMENTS

! WARNING

All adjustment operations must be performed with the tractor engine off, the PTO disengaged, the machine lowered to the ground or on security stands, the parking brake set and the ignition key off. Secure blocking prevents equipment from dropping due to hydraulic leak down, hydraulic system failures, or mechanical component failures.

WORKING DEPTH ADJUSTMENT

The working depth of the machine is determined by the position of the rear roller. The rear roller performs following functions:

- determine the working depth of the tools into the soil,
- Leveling and re-compacting the soil, reducing the excessive softness subsequent to soil working, and assuring a good contact of the seeds with the soil moisture.

The roller is supported by a frame linked to the side plates of the machine by means of two swinging arms.

The position of the roller can be adjusted by the operator manually (in case the machine is provided with adjustment by pins or mechanical jacks), or hydraulically (in case the machine is provided with hydraulic jacks), as described in the following paragraphs.

! DANGER

Crushing hazard: The roller is very heavy; all adjustment operations must be performed only by use of support stands that prevent the accidental dropping of the machine.

ROLLER ADJUSTMENT BY PINS

For adjustment of roller assembly both side of hull plate 'A', holes are provided for roller adjustment pin 'B'. Roller mounting plate of roller assembly pivoted by pin C at hull side plate. roller adjustment pins are the restrict the swinging of roller and by its position of roller can adjust by inserting pins 'B' in different holes as shown in picture.

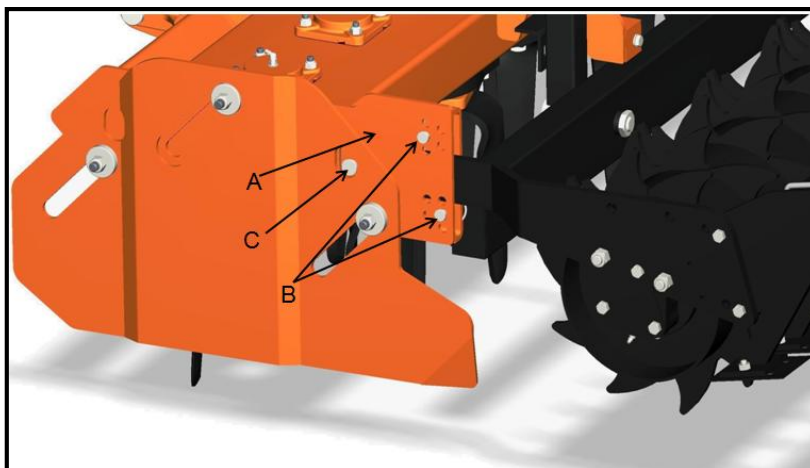

Operator can adjust the roller height in eight different positions, by inserting the two adjusting pins (B) into the holes immediately above and below the roller's swinging arms, according to the desired working height.

LIGHT POWER HARROW

The maximum roller height from the ground is got positioning the roller between the upper connecting pin (C1) and the lower adjusting pin (D2) (see picture below - left). The minimum roller height from the ground is got positioning the roller between the upper adjusting pin (D1) and the lower connecting pin (C2) (see picture below - right).

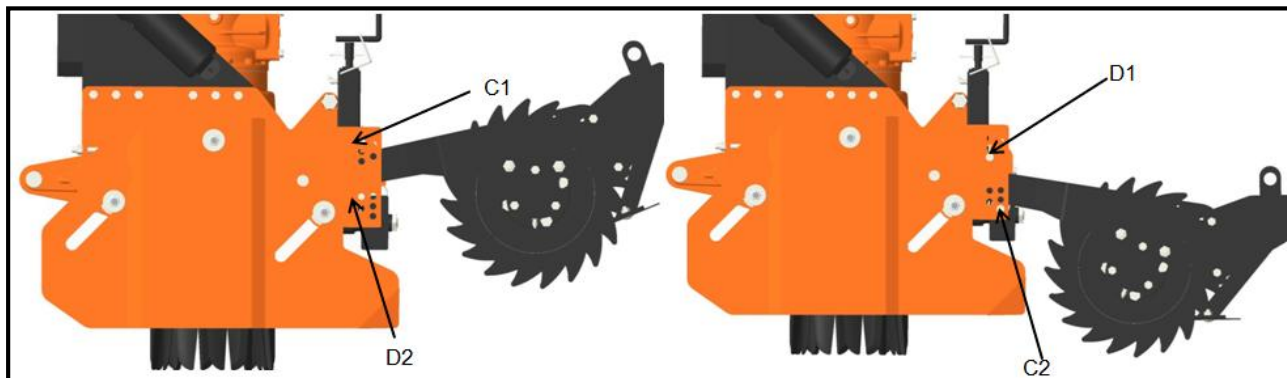

The roller can be left in floating configuration, free to follow the ground contour, by positioning the adjusting pin (D2) in a hole lower to position (E) immediately below to the connecting arm, or by removing it altogether.

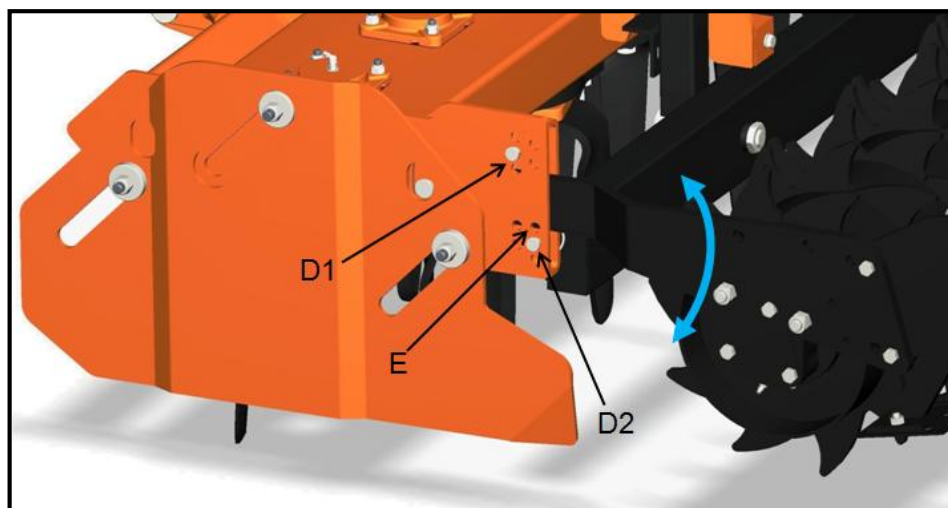

This configuration can be useful in case the machine meet an obstacle during operation, allowing the machine to overcome it without damaging the roller, thanks to the swinging arms, and obtaining a nearly uniform leveling of the ground.

WARNING

Always make sure to position the roller at the same height on both sides of the machine, by checking that the pins are inserted in the corresponding hole positions of the side plates.

LEVELLING BAR ADJUSTMENT

The leveling bar is positioned between the rear roller and the power harrow frame, to which is connected through two mechanical adjustment jacks.

The leveling bar, together with the side plates, allows retaining the thickest clods in the working area of the rotors, ensuring the complete crumbling of the soil in aggregates of small size, thereby improving the soil refining, and generates leveling action before the passage of the roller.

The bar is adjustable in height through the two side jacks (A). To adjust the bar height, operator must rotate the crank (B) until the desired height is reached (see picture below).

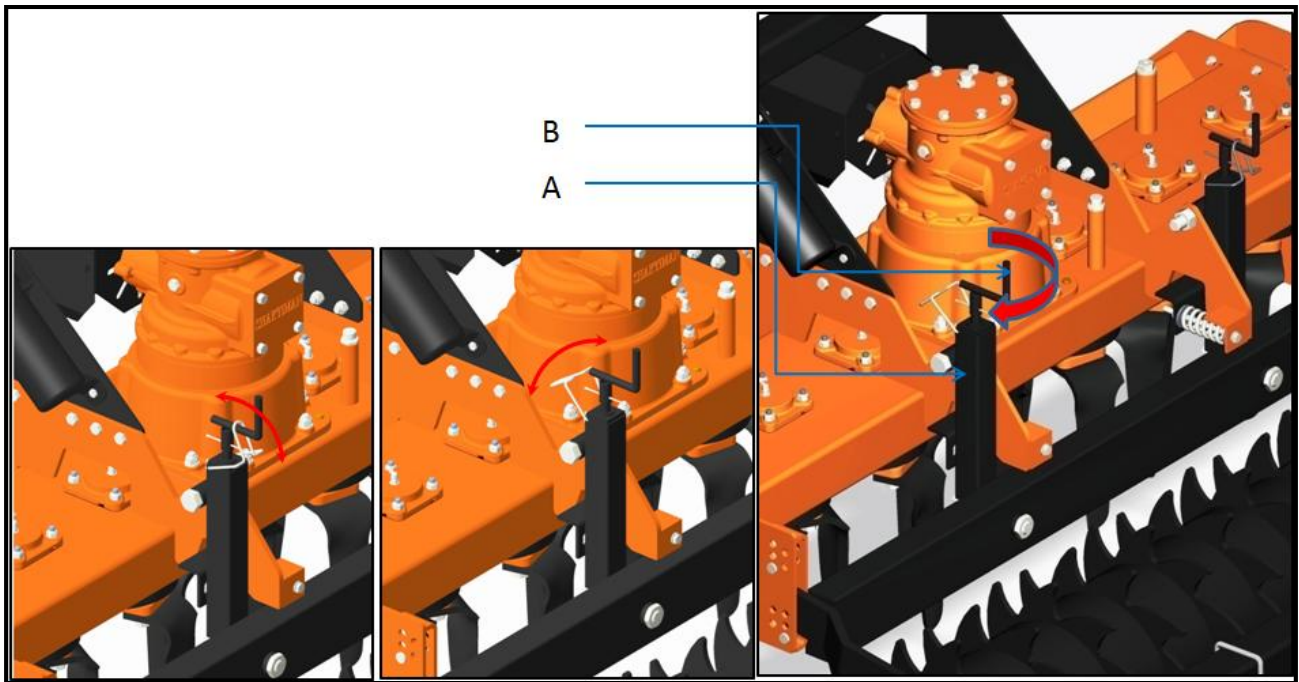

It is recommended to set the bar position at 4-5 cm higher compared to the position of the roller on the ground.

! WARNING

Always make sure that the leveling bar is positioned at the same height on both sides, through the suitable indicator of the jack.

SIDE PLATES ADJUSTMENT

The side plates allow retaining the thickest clods in the working area of the rotors, preventing it from coming out and from accumulating in external ridges.

The plates can be adjusted in height, to be adapted to different types of working conditions (with more or less abundant production of fine soil), and to take into account the knives consumption.

To perform the side plate's adjustment (see picture):

- remove the four nuts from bolts (A);
- shift the mobile plate (B) until the position required;
- retight the fixing bolts with nuts.

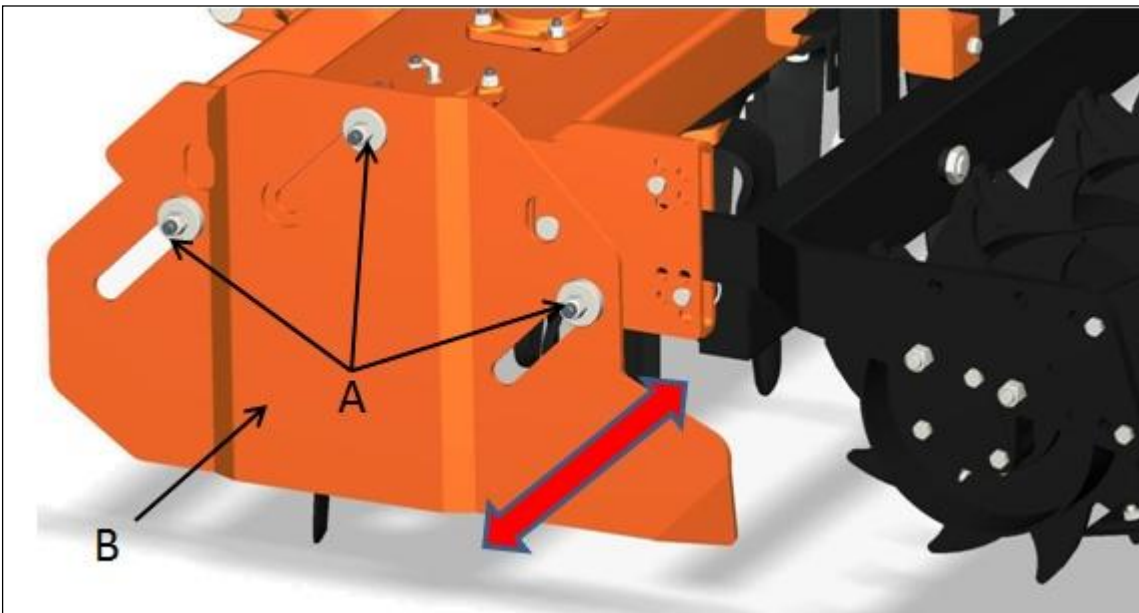

FRICITION CLUTCH ADJUSTMENT

If the machine is equipped with a PTO shaft with friction discs clutch, the safety device protects the machine from overloads during use through the slipping of the clutch discs, and limits the maximum torque transmitted from the tractor to the machine at a predetermined value, thanks to the springs height preset at the factory (see picture).

It is therefore recommended to leave the spring's height value unchanged to avoid damage to the machine or to the PTO shaft.

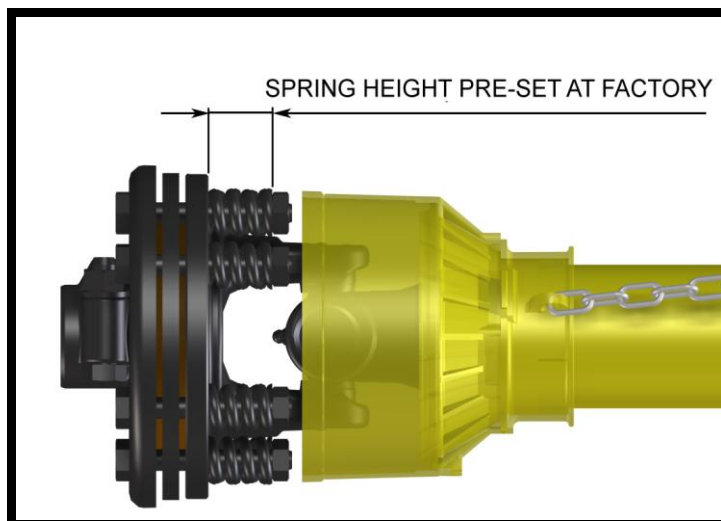

An adjustment can be done, however, when the clutch slipping is too frequent, which means that the calibration is too low. In this case, the tightening of nuts over the compressed springs will give an increase in torque transmissible. On the contrary, a loosening of the nuts over the springs will give a decrease in torque transmissible.

IMPORTANT

For details about clutch adjustment, refer to the user manual of the Manufacturer of the driveshaft installed. The Manufacturer is not liable for damages resulting from a wrong modification of the clutch calibration.



NOTES

Excessive tightening of the springs can prevent the clutch from slipping and to protect the machine from overload.

Make sure that the height of all the compressed springs is equal to prevent clutch malfunctioning.

5.4. STOPPING AND DISCONNECTION

To stop the machine at the end of a working session:

- bring the tractor on a dry and level surface;
- stop the tractor and place the transmission in park or neutral;
- reduce the engine speed, then disengage the PTO;
- wait for stopping of all rotating parts;
- lower the implement to the ground;
- set the parking brake;
- shut down the engine and remove the key before exiting the tractor;
- Do the cleaning and maintenance required to make the machine ready for later use (see section Maintenance).



WARNING

Never leave the tractor unattended with the implement in the lifted position.

To disconnect the machine from the tractor (e.g. to make a change of implement):

- bring the tractor on a dry and level surface;
- stop the tractor and place the transmission in park or neutral;
- reduce the engine speed, then disengage PTO;
- wait for stopping of all rotating parts;
- lower the implement to the ground;
- set the parking brake;
- shut down the engine and remove the key before exiting the tractor;
- disconnect the driveline from the tractor PTO and rest it on and store in appropriate place;
- disconnect the top link and the rear lifting arms of the tractor from the machine hitches;
- Check the machine stability. If needed, place safety blocks to prevent unit from tipping;
- get on the tractor, start the engine and move away from the machine slowly;
- Make sure that the machine remains stored in a protected area, to prevent that unauthorized personnel can approach it.

Before a long term storage (e.g. at seasonal end), do cleaning and maintenance operations as specified in sections Maintenance and Storage.

5.5. TRANSPORT

To set the machine for transportation, when connected to the tractor, perform the following steps:

- idle tractor engine, disengage tractor PTO, and wait for stopping of all rotating parts;
- lock the tractor lifting hydraulics, turn off the engine, set the parking brake, remove ignition key and get off the tractor;
- be sure that the tractor's lifting arms are locked horizontally, to prevent the machine from swinging, compromising the stability of the tractor and the machine;
- Check the lifting capacity and stability of the tractor connected to the machine in transport position (see section "Tractor-machine stability"), and apply to the tractor a ballast of at least 20% of tractor and implement weight. Without ballast, the front wheels of the tractor could lift up, resulting in loss of steering control and braking. Ballast can be added to the front wheels or to the front of the tractor;
- Lift the machine until the transport position (approx 35-40 cm from the ground), making sure the driveline transmission tubes does not hit either the tractor or the machine gearbox. A minimum gap of 2 cm should be leaved between the tubes and tractor and machine (see also section Driveline installation).



CAUTION

Make sure PTO is disengaged and blades have stopped turning before raising the machine to transport position.



WARNING

Never leave the tractor unattended with the implement in the lifted position.

During transportation:

- Always use caution and select a safe ground speed appropriate for the terrain. Reduce speed when under adverse surface conditions, turning, or on inclines. Take care that the implement does not strike obstacles such as trees, fences or buildings;
- do not operate PTO. Always transport the implement with disengaged PTO;
- do not transport on steep slopes;
- do not transport equipment while under the influence of alcohol or drugs;
- do not use the machine to transport people, animals or things;

During transportation on public roads:

- install all the warning devices required by current regulations for transit (rear reflectors, lighting systems, flashing, Slow Moving Vehicle signal and/or Protruding Moving Vehicle signal);
- Always comply strictly with all federal, state and local laws and traffic regulations.



WARNING

When driving on public roads, reduce your speed, be aware of traffic around you and proceed in such a way that faster moving vehicles may pass you safely.

Always use tractor lighting system and auxiliary lighting system for adequate warning to operators of other vehicles, especially when transporting at night or in conditions of reduced visibility.

6. MAINTENANCE

Proper and regular maintenance ensures a long life of your implement avoids failures and saves time and repair costs.

Periodic inspections and maintenance operations described in this section must be performed by operator in the times and terms prescribed. Failure to comply with maintenance prescriptions can compromise the functioning and duration of the machine, and consequently invalidate the warranty.

The frequency of maintenance indicated refers to normal conditions of use: it must be intensified in severe or in usual operating conditions (frequent stops and starts, prolonged cutting season etc...).

Repairs, maintenance and modifications other than those mentioned in this paragraph should NOT be performed without consulting the Manufacturer or your Dealer. Manufacturer, as the case, may give the authorization to proceed with the repair together with all necessary instructions.

Wrong or inappropriate repairs or maintenance may generate abnormal operating conditions, equipment damage and generate risks for the operator.

IMPORTANT

Before perform any maintenance operation, be sure to read and understand the information relating to safety instructions listed in the section "Maintenance safety instruction" of this manual.



WARNING

For safety reasons, all maintenance operations must be performed with tractor PTO disengaged, machine stopped and completely lowered to the ground or onto support blocks, parking brake set, tractor engine shut off, and ignition key removed.



WARNING

Perform maintenance operations always using appropriate Personal Protective Equipment (protective eye glasses, hard hat, safety shoes, overall and work gloves, filter mask).

6.1 TOOLS REPLACEMENT

Frequently check the wear of the tools on the rotors through visual inspection. The wear of the blades is very variable depending on the type of soil.

The replacement of tools is necessary when they are damaged (deformed, cracked or broken) for accidental reasons following the working operations, or when their dimensions are significantly reduced compared to the original.

IMPORTANT

The length of the blades should never be less than 150 mm (see picture below).

Operating the machine with tools in bad condition compromises the quality of work and may damage the machine.

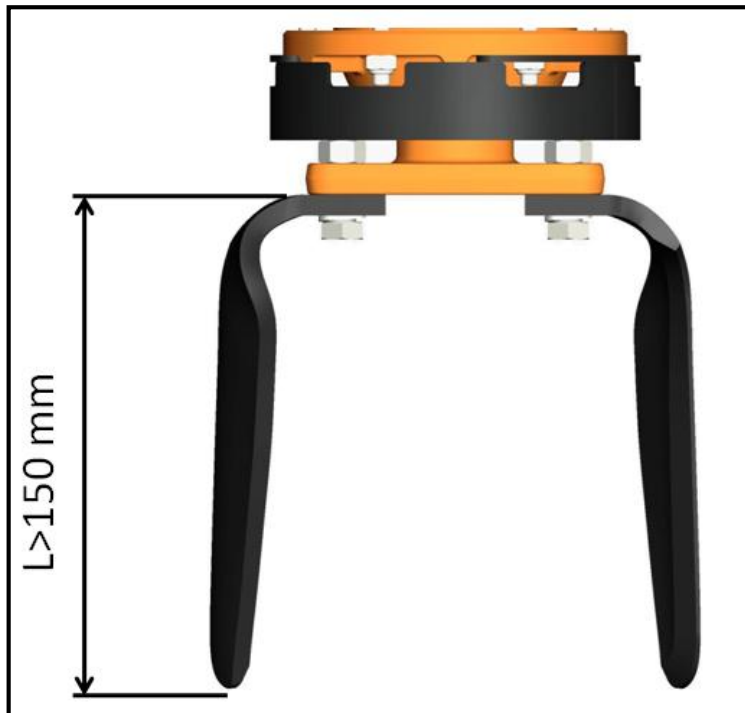

Before perform the replacement of the tools:

- idle tractor engine, set the parking brake, disengage tractor PTO, and wait for all moving parts to come to a complete stop;
- place the machine slightly raised off the ground on blocks or safety stands;
- lock the hydraulic lift of the tractor;

Switch off the engine and remove the key from the control panel.

LIGHT POWER HARROW

Blades are assembling in rotor flange (D) by bolts (A) and spring washers (B) and nuts(C) by which bolts (A) fits whole assembly.

To perform the replacement of the blades do following steps (see picture below):

- Remove the nuts, bolts and washers by spanner or tool kit.
- At a time of remove the bolts (A) and spring washers (B) remove the worn blade;
- Position a new blade exactly instead of the worn blade. Be sure to install the blade with the cutting edge in the same direction of the previous one (same sense of rotation than the rotor);
- Replace bolts and spring washers, retightening them to the screws stopping. Refer to the "Torque values table" of the manual for identify proper torque values;
- replace the stone protection cover (where provided);
- Repeat the same procedure for the second blade of the rotor and for all the rotors.

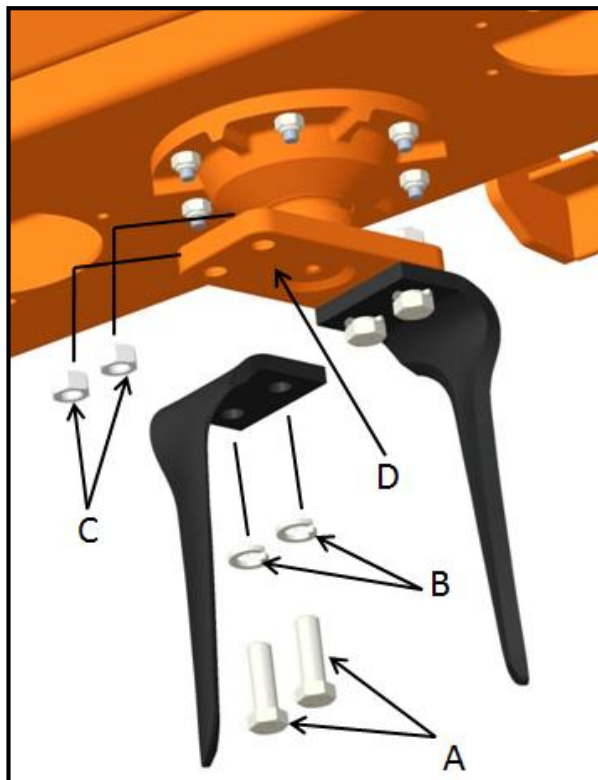

WARNING

Blades on contiguous rotors have different orientations (right blades and left blades): always install the new blades with cutting edge having the direction of rotation of the rotor flange which they are connected to.

Worn blades can be very sharp! Apply extreme caution in handling.

IMPORTANT

Remove and install one blade at a time to ensure that blades are correctly oriented when installed.

Periodically check the tightness of screws and nuts, and tighten if necessary.

Replace worn blades only with original spare parts provided by the manufacturer or your Dealer.



WARNING

LIGHT POWER HARROW

The machine has been designed with an arrangement of contiguous rotors having diversified angles, to allow the gradual entry of the blades into the soil, with consequent reduction of vibrations transmitted to the tractor and reduction of fuel consumption.

In case the replacement of one or more rotor flanges is required, it is essential to respect the original assembly layout. In case of any doubt contact the Manufacturer or the Dealer.

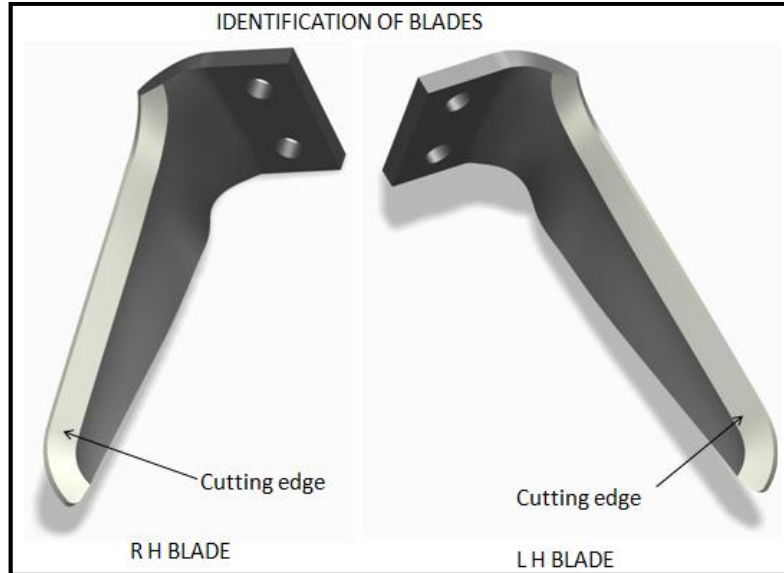

FITTING PATTERN OF BLADES

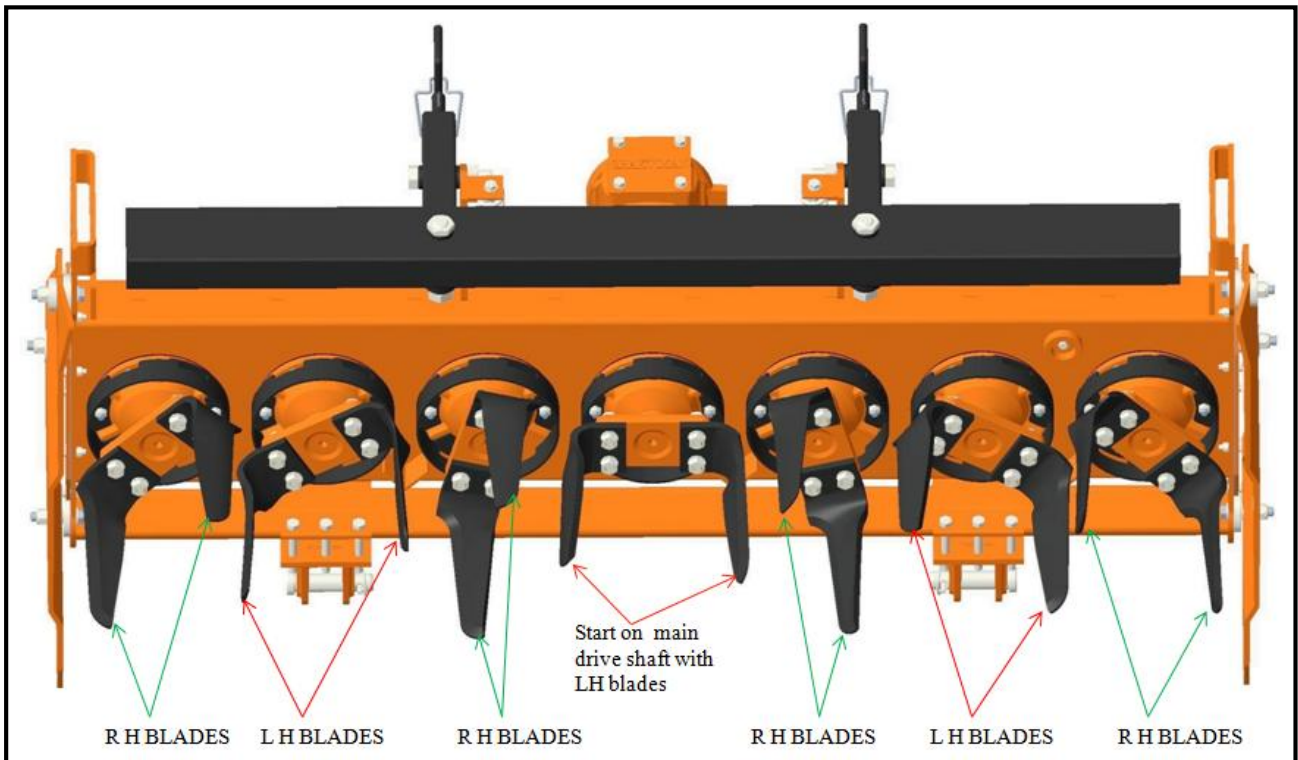

LIGHT POWER HARROW

- Both Blades fitting on flange of main shaft should be LHS.
- The blades on adjacent flanges will be RHS on either sides.
- The same patter will follow for further adjacent flanges.

Model	No. of LHS blades	No. of RHS blades	Total No. Of Blades
SRP-125	6	4	10
SRP-150	6	6	12
SRP-175	6	8	14
SRP-200	8	8	16

6.2 SCRAPER PLATES REPLACEMENT (PACKER ROLLER)

The packer roller is equipped with a rear bar supporting a series of scraper blades, which have the function to clean the roller by the accumulation of the soil. The optimal distance between the roller and each scraper is 2-3 mm.

Frequently check the wear of the scrapers, and provide for the replacement of the blades excessively worn, in order to assure a more efficient cleaning of the roller.

To perform the substitution of a scraper blade (see picture below):

- unscrew the mounting nut & bolts (1) and remove the blade (2);
- position the new blade on the support (3) through the bolts and tighten them only partially;
- Slide the blade on the support through the slots, until the desired distance from the roller is reached (distance suggested: 2-3 mm), then complete the tightening of the bolts. For the correct torque values refer to the section "Torque values table" of the manual.

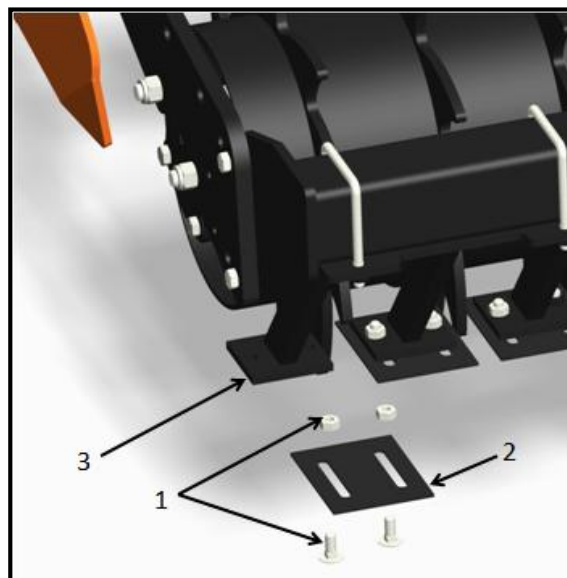

IMPORTANT

At the first use, or after replacement of the blades, it is suggested to adjust the blades after few minutes of machine working.

6.3 GEARBOX LUBRICATION

Lubricant: SAE 85W/140 gear oil.

Check the oil level every 50 hours, (A) is located between the two reference marks (minimum and maximum).

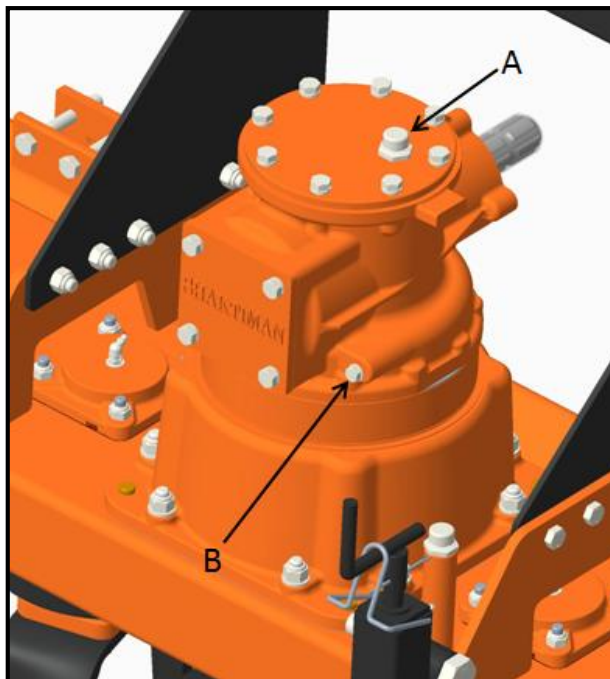

If the mark is below the minimum, fill up oil till the correct level is restored.

The oil change must be performed:

- after the first 50 working hours;
- Each 400 working hours.

To make oil change:

- place a tank under the oil drain plug (B) at the bottom of gearbox;
- unscrew the oil drain plug and drain oil completely into the tank;
- retighten the drain plug;
- unscrew the oil filling plug (A);
- fill up oil till restore the correct level (between the two reference marks on dipstick) ;
- retighten the filling plug;
- Dispose the discharged oil into containers for used oil.



CAUTION

Before touching the gearbox wait until it has cooled sufficiently.

IMPORTANT

Frequently check possible oil leaks from the machine through visual inspection, and in case of leakage provide immediately proper maintenance.

Avoid oil leaks on the ground when restoring oil level or making oil change.

6.4 GEARS TROUGH LUBRICATION

Lubricant: SAE 85W/140 gear oil.

Check the oil level every 50 hours, making sure that the mark left from the oil on the dipstick of the filling plug (A) on the frame is located **between the two reference marks** (minimum and maximum).

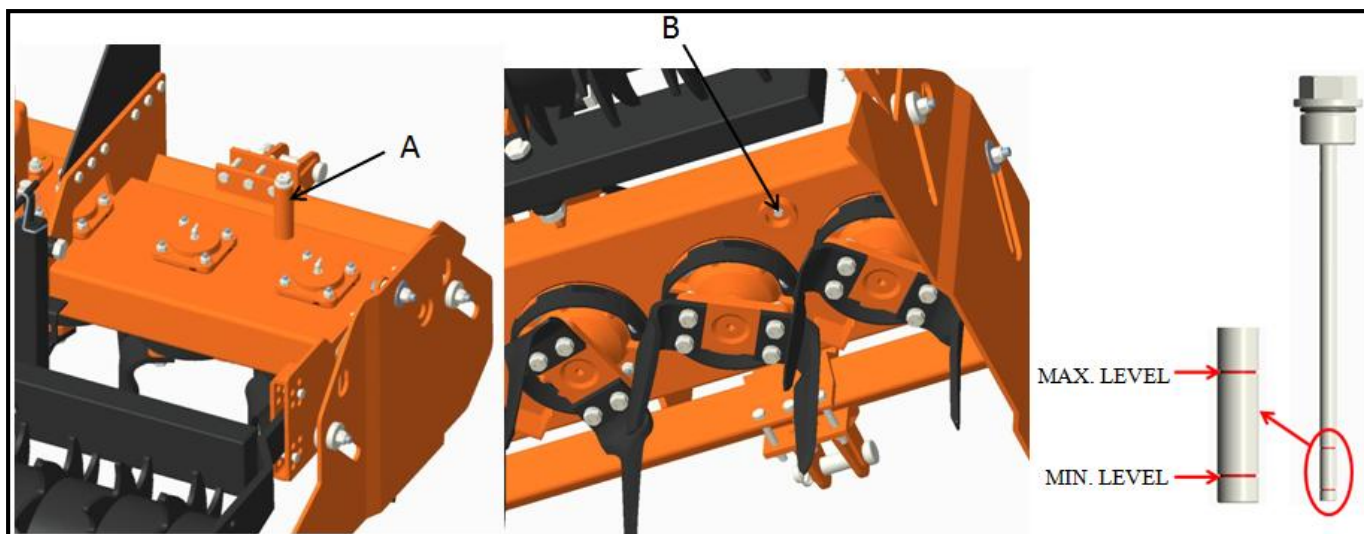

If the mark is below the minimum, fill up oil till the correct level is restored.

The oil change must be performed:

- after the first 50 working hours;
- Each 400 working hours.

To make oil change:

- place a tank under the oil drain plug (B) at the bottom of the frame;
- Remove oil drain screw (B) placed at right side and bottom of hull frame.
- unscrew the oil drain plug and drain oil completely into the tank;
- retighten the drain plug;
- unscrew the oil filling plug (A);
- fill up oil till restore the correct level (between the two reference marks on dipstick);
- retighten the filling plug;
- Dispose the discharged oil into containers for used oil.

Power Harrow Oil Quantity Chart (Litre)		
Model	Oil Qty in Gear Box	Oil Qty in Secondary Drive
SRP-125	1.5	10
SRP-150	1.5	12
SRP-175	1.5	14
SRP-200	1.5	16

6.5 REAR ROLLER BEARINGS LUBRICATION

Lubricant: **SAE multi-purpose lithium-type grease.**

The rear roller's bearing housings are built with pre-lubricated sealed bearings. Exposure to water or dust, however, requires occasional republication with high quality grease.

It is suggested to grease the bearings every 50 hours, till to observe the first losing fat from the outer ring of the bearing, in order to prevent overfilling.

The greasing point is shown in the figure below.

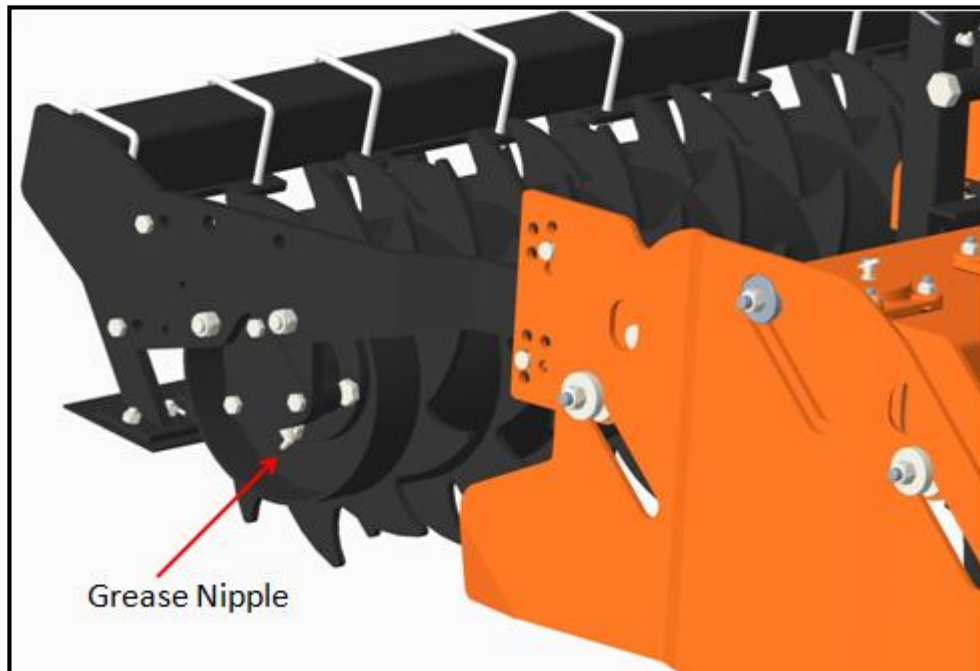

IMPORTANT

Make sure to clean the fitting jerk before using the grease gun.

Do not let excess grease collect on or around parts, particularly when operating in sandy areas.

6.6 SECONDARY DRIVE BEARING AND LEVELING BAR SCREW LUBRICATION

Lubricant: SAE multi-purpose lithium-type grease.

The secondary drives bearing and leveling bar handle screw are frequently needed to provide lubrication for smooth and better working. Exposure to water or dust, however, requires occasional republication with high quality grease.

It is suggested to grease the bearings every 50 hours, till to observe the first losing fat from the outer ring of the bearing, in order to prevent overfilling.

The greasing point is shown in the figure below.

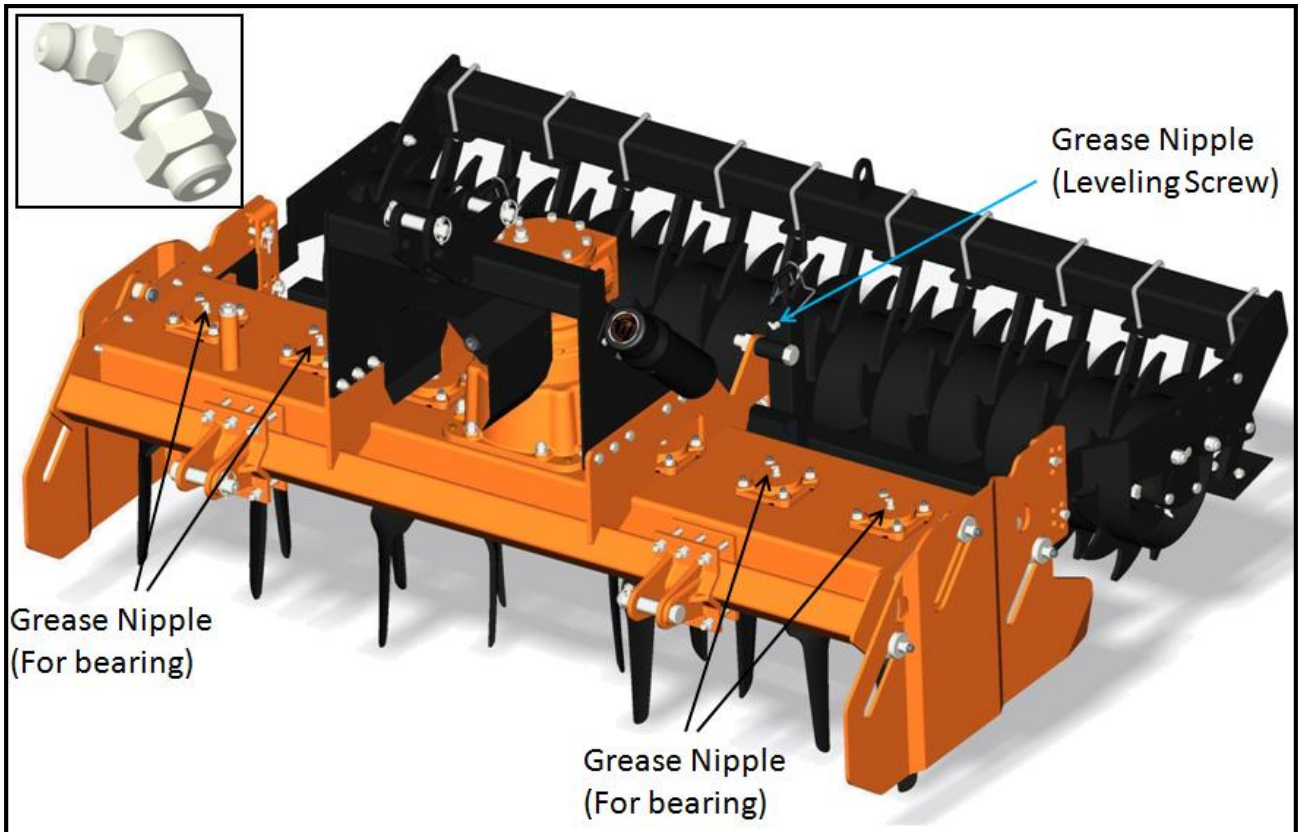

IMPORTANT

Make sure to clean the fitting jerk before using the grease gun.

Do not let excess grease collect on or around parts, particularly when operating in sandy areas.

6.7 DRIVESHAFT MAINTENANCE

Lubricant: SAE multi-purpose lithium-type grease

Grease crosses, sliding parts of protective shielding and driveshaft transmission tubes.

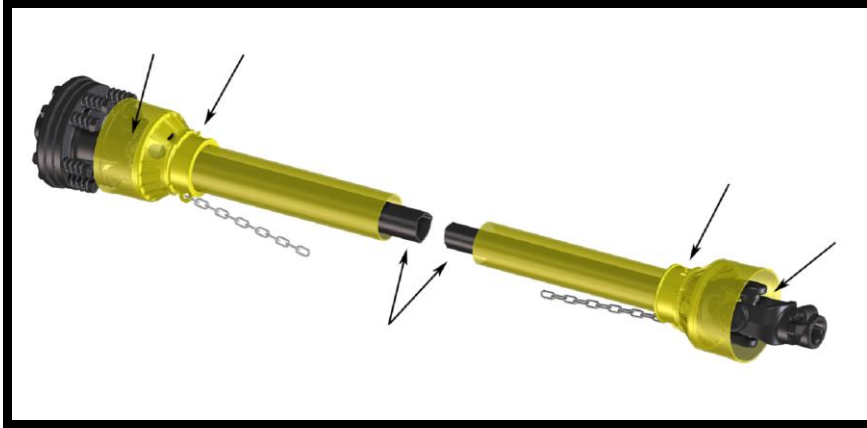

IMPORTANT

For details about maintenance and lubrication of the driveshaft, refer to the user manual of the driveshaft Manufacturer.

If the machine is equipped with a PTO shaft with friction discs clutch, exposition to the elements of the machine and driveshaft, or a long period of inactivity, generally results in oxidation of some clutch components, and creates "sticking" effect on the clutch.

Consequently, the torque required to the slippage of the clutch could increase considerably compared to the value set at factory, and this may be cause of driveshaft breakage during operation, or damage to the tractor or implement.

To avoid it, before re-using the machine, operator must perform a short "run-in" of the clutch, as follows:

- take note of the height of the compressed springs;
- loosen the bolts that compress the springs;
- connect the machine to the tractor (see section Connecting to the tractor) ;
- connect the driveshaft (see section Driveline installation) ;
- start the tractor and engage PTO for few seconds, in order to cause slippage and separation of the parts "sticked" of the clutch;
- turn off the tractor, remove key and wait for all components are stopped before dismounting from tractor;
- Retighten the bolts restoring the original spring's position on the driveshaft.

NOTE

For replacement of the driveshaft service parts (e.g. friction discs), refer to the user manual of the driveshaft Manufacturer.

7. STORAGE

Before leaving the machine unused for a long time, it's necessary to carry out following tasks to preserve the appearance and functionality of the machine, and to make easier the restart at later use:

- park the machine on a flat surface, in a dry place protected from exposition to the elements, if possible with temperature between 0 and 50 °C (see section Stopping and disconnection);
- thoroughly clean the machine, and remove from the rotors all residues due to soil working, in order to avoid damage from grass and stagnant water;
- Inspect carefully the machine, checking for worn and/or damaged parts. Perform immediately all repairs and/or replacements needed, in order to make the machine ready for restarting;
- in case of abrasion of painted surfaces, provide restoring the surface protection through touch-up paint, in order to prevent rust;
- Make sure the safety decals are in their original positions, intact and legible. When required, replace the decals immediately;
- Lubricate properly all grease points, and restore oil levels as indicated in the Maintenance section. Use protective oil to coat the exposed mechanical components and to protect them against rust.

If the connecting driveshaft is equipped with a friction discs clutch, it is suggested to take note of the height of the compressed springs and loosen the bolts that compress the springs, to prevent the "sticking" effect of the discs due to moisture, that may cause clutch failure at restart of the activities (see also Driveshaft maintenance).

Before restart the operations, restore the original height of the springs.

8. SCRAPPING

In case of scrapping, the machine must be disposed in appropriate and authorized sites, according to local legislation of the Country where the machine is used.

Before scrapping, separate plastic parts from rubber parts, aluminum, steel, etc. and dispose the parts to authorized centers.

Recover and dispose any exhausted oils to authorized centers for oil collecting.

IMPORTANT

Respect the environment. Store and/or dispose any exhausted lubricants as indicated by lubricant Manufacturer.

9. TROUBLESHOOTING

PROBLEM	POSSIBLE CAUSE	POSSIBLE SOLUTION
Noise from cardan shaft during machine lifting	Bad connection between machine and tractor	Adjust the tractor top link
	Machine is lifted too much	Limit the lifting
Noise noticeable and constant from gearbox/gears transmission trough	Low oil level	Add oil
	Worn gears	Replace gears
Intermittent noise from the machine	Loose blades	Tighten blades hardware
	Gear tooth damaged	Replace damaged gear
Noise and/or vibration from machine	Blades worn or damaged	Replace blades
	Bearings worn or damaged	Replace bearings
	Rotor(s) damaged	Repair/replace rotor(s)
	Rotors/blades incorrectly installed (incorrect rotor arrangement and/or blades orientation)	Install rotors/blades correctly (follow rotors arrangement shown in the manual and /or reinstall blades with correct orientation)
	Front of the machine not leveled to the back	Adjust 3-point tractor top link making input connection shaft parallel to the ground
	Machine not stable at sides	Lock tractor lifting arms to prevent machine swinging
	Hard soil	Reduce ground speed
Driveline vibration	Worn driveshaft	Replace driveshaft
	Machine lifted too high	Lower machine and readjust tractor top link
	Debris wrapped around blades and/or rotors	Remove debris
Rotor stops turning	Slip clutch slipping	Reduce load to the machine or adjust slip clutch
	Broken gear(s) in gearbox/ /gears transmission trough	Replace gear(s)
Smoke and/or hot smell from the machine	Debris wrapped around blades and/or rotors	Remove debris
	Low oil level	Add oil
	Slip clutch slipping	Reduce load to machine or adjust slip clutch
Gearbox/gears transmission trough overheating	Low oil level	Add oil
	Hard soil	Reduce ground speed
Blades wear frequently	Muddy or sandy soil	Reduce ground speed
Blades break frequently	Stony soil	Reduce ground speed
Oil leaking from gearbox/	Gearbox/gears transmission	Drain to proper level

LIGHT POWER HARROW

gears transmission trough	trough overfilled	
	Loose filling/drain plug	Tighten filling/drain plug
	Damaged breather plug	Replace breather plug
	Damaged seals	Replace seals
Working depth insufficient	Hard soil	Reduce ground speed. Do soil working in more steps
	Required transmission of higher load from the tractor	Increase PTO speed
	Machine too raised from the ground	Raise rear roller
	Blades worn or bent	Replace blades
	Rotors/blades incorrectly installed (incorrect rotor arrangement and/or blades orientation)	Install rotors/blades correctly (follow rotors arrangement shown in the manual and /or reinstall blades with correct orientation)
	Debris wrapped around blades and/or rotors	Remove debris
Soil texture too coarse	Leveling bar too high	Lower leveling bar
	Hard soil	Reduce ground speed. Do soil working in more steps
	PTO speed too low	Increase PTO speed
	Ground speed too high	Reduce ground speed
Soil texture too fine	Leveling bar too low	Raise leveling bar
	Crumbly soil	Increase ground speed
	PTO speed too high	Reduce PTO speed
	Ground speed too slow	Increase ground speed
Machine choking up with soil	Blades worn or bent	Replace blades
	Rotors/blades incorrectly installed (incorrect rotor arrangement and/or blades orientation)	Install rotors/blades correctly (follow rotors arrangement shown in the manual and /or reinstall blades with correct orientation)
	Soil too wet	Wait until soil dries
	Ground speed too fast	Reduce ground speed
	Excessive working depth	Lower rear roller
Machine skipping on ground, vibrating or leaving crop residue	Blades worn or bent	Replace blades
	Clutch slips too frequently	Lower the tractor load transmitted to the machine or adjust the clutch
	Rotors/blades incorrectly installed (incorrect rotor arrangement and/or blades orientation)	Install rotors/blades correctly (follow rotors arrangement shown in the manual and /or reinstall blades with correct orientation)
	Debris entangled in rotors and/or blades	Clear rotors and/or blades
	Ground speed too fast	Reduce ground speed
	Soil too hard	Reduce ground speed. Do soil working in more steps
Soil appears not uniform after working	Blades worn or bent	Replace blades
	Left side of the machine not	Adjust the tractor lifting arms

LIGHT POWER HARROW

	leveled to the right	and/or the rear roller and/or the leveling bar position
	Ground speed too fast	Reduce ground speed
Too load required to tractor	Excessive working depth	Lower rear roller
	Excessive PTO speed	Reduce PTO speed
	Ground speed too fast	Reduce ground speed
	Leveling bar too low	Raise leveling bar
Soil accumulation between rotor and leveling bar	Soil too wet	Wait until soil dries. Remove leveling bar
Obstruction/blockage of Packer roller	Blades scrapers worn and/or in incorrectly position	Replace scrapers and/or adjust position
	Plant residues obstructing blades scrapers	Remove residues and clean scrapers
Soil accumulation ahead of Packer roller, resulting in Roller stop	Soil too sandy	Extend 3-point tractor top link
		Reduce ground speed
		If possible, use roller with increased diameter
Obstruction/blockage of Cage roller	Soil too wet	Wait until soil dries. Use Packer roller

10. TORQUE VALUES TABLE

Frequently check hardware to make sure that screws and bolts are tightened according to torque values listed in following table (friction coefficient: 0.14):

STD.		Grade (new)		4.8		5.8		6.8		8.8		10.9		12.9	
DIN 267		Grade (old)		4 S		5 S		6 S		8 G		10 K		12 K	
SCREW	Wrench	Pitch		Pitch		Pitch		Pitch		Pitch		Pitch		Pitch	
		DIAM.	dimens.	Coarse	Fine	Coarse	Fine	Coarse	Fine	Coarse	Fine	Coarse	Fine	Coarse	Fine
mm.	mm.	mm.	mm.	Nm.	Nm.	Nm.	Nm.	Nm.	Nm.	Nm.	Nm.	Nm.	Nm.	Nm.	Nm.
M 8	13	1,25	1	13	14	16	17	19	20	25	27	35	38	42	46
M 10	17	1,5	1,25	25	26	31	33	37	39	50	53	70	74	84	89
M 12	19	1,75	1,5	42	45	53	56	64	67	85	89	119	125	143	150
M 14	22	2	1,5	68	74	84	92	101	111	135	148	190	208	228	250
M 16	24	2	1,5	106	113	132	141	159	170	212	226	298	318	357	382
M 18	27	2,5	2	145	155	182	194	218	233	290	310	402	436	490	523
M 20	30	2,5	2	206	218	258	273	310	327	413	436	580	614	697	736
M 22	34	2,5	2	284	299	355	373	426	448	568	597	798	840	958	1008
M 24	36	3	2	357	390	446	488	535	586	714	781	1004	1098	1204	1317
M 27	41	3	2	525	570	656	712	788	855	1050	1139	1477	1602	1772	1923
M 30	46	3,5	2	714	795	893	994	1072	1193	1429	1590	2009	2236	2411	2648
M 33	50	3,5	2	970	1068	1213	1335	1456	1602	1941	2136	2729	3004	3275	3605
M 36	55	4	3	1248	1326	1561	1658	1873	1989	2497	2652	3511	3730	4213	4476
M 39	60	4	3	1621	1715	2026	2144	2431	2573	3242	3430	4559	4824	5471	5789
M 42	65	4,5	3	2005	2175	2507	2718	3008	3262	4011	4349	5640	6116	6768	7339
M 45	70	4,5	3	2520	2701	3149	3376	3779	4051	5039	5401	7086	7596	8503	9115

11. WARRANTY

M/s. Tirth Agro Technology Pvt. Ltd. offer the following warranty to the purchaser of SUNDOWN equipment mentioned herein above subject to the conditions set out herein after provided the SUNDOWN equipment shall be in the possession of and used by such purchaser from the date of delivery.

M/s. Tirth Agro Technology Pvt. Ltd. Warrants its products for a period of twelve (12) months from date of delivery, for manufacturing or material defects only. Failed part will be replaced at its authorized dealers only and any part component there of that shall be examined by them, shall disclose if to be defective. This warranty shall not apply to equipment or parts that have been subject to negligence, or accident, or not maintained as per company instructions specified in operator manual or that have been altered or repaired or used with non-genuine parts or abused or due to contaminated oil or used in not recommended application.

Warranty Terms & Conditions:

- 1) The purchaser of SUNDOWN equipment should strictly follow the instruction given in the instruction manual provided by the company along with the SUNDOWN equipment at the time of delivery. Changes if any, resulting in improper usage will not be covered by the warranty. This warranty will automatically terminate on the expiry of warranty period of Six months even the SUNDOWN equipment may not be in use for any time during the warranty period for any reason whatsoever including any technical reasons and time taken for such repairs/replacement of parts, and in transit, whether under this warranty or otherwise shall not be excluded from the warranty period.
- 2) All wear and tear items like bearings, chains, sprockets, oil seals, tines, blades, rubber parts and gaskets are not covered under warranty.
- 3) All items with normal wear or failure due to normal wear will not be covered under warranty.
- 4) While the company or authorized dealers will make every effort to carry out repairs/replacement of parts under this warranty as soon as possible. It is expressly made clear that the company shall not be liable to do within any specific period of time.

In the event of repairs/replacement of any parts, this warranty will thereafter continue to remain in force only for the unexpired period of warranty.

- 5) It is entirely left to company discretion to repair/replacement of parts at the site of delivery or at the authorized service points of its dealers. The defective parts which has/have been agreed to be replaced, should be returned to the company without any further claim.
- 6) The warranty shall not cover any consequential or resulting liability, damage or loss arising directly or indirectly out of any defect in the SUNDOWN equipment. This warranty shall be strictly limited to repairs and replacement of the defective parts specified in the warranty, and
does not cover any reimbursement of labour charges for any repairs so earned out at dealer/client end.
- 7) This warranty shall not be extended in any case of replacement or return of the SUNDOWN equipment as a whole. Only failed parts will be covered under warranty.
- 8) The purchasers of SUNDOWN equipment will itself fully responsible for model/variant selection.

LIGHT POWER HARROW

- 9) This warranty does not cover for statutory duties and taxes like excise, service tax or CST or VAT or State sales tax and octroi and any other local taxes payable on any of the parts which the company may supply or repairs free of cost during the warranty period.
 - 10) This warranty also does not cover the cost of packaging, to and fro freight and transportation charges etc., on the defective SUNDOWN equipment or other parts of the SUNDOWN equipment sent to company's works in Rajkot or to the authorized service station.
 - 11) Warranty becomes void if:
 - a) The SUNDOWN equipment has not been delivered, assembled, started and put into operation by the company or its authorized representative.
 - b) The dully filled delivery certificate is not in our possession within 15 days from the date of delivery.
 - c) The SUNDOWN equipment or any parts thereof is subjected to neglect, fire, floods or other acts of God or if in the company's opinion any damage has caused to the SUNDOWN equipment during transportation.
 - d) The original serial number is removed, obliterated or altered from the unit.
 - e) Any attempt is made to have the repairs executed by a person or persons, other than the company or its authorized representative.
 - f) Any defect is not informed immediately to the company or its authorized representative, any alteration in warranty card is made.
 - g) Whenever the user or anyone else on his behalf applies equipment to the tractor or to prime mover that has not been expressly approved by the manufacturer or not suitable to the equipment.
 - 12)
 - a) Any changes in the location of the SUNDOWN equipment or in the/its ownership thereof during the warranty period must be intimated in writing to the company or its authorized dealer within ten days before the change. Failure to do so will absolve the company from the obligation under this warranty.
 - b) Further, in the case of shifting for the continuation of the Warranty, the SUNDOWN equipment has to be inspected by the company or its authorized representative before shifting from the original location and before using it at the new location. The inspection free levied by the company or its authorized representative as well as the cost of rectification of any damage in transit, detected in the above inspection, shall be borne by the purchaser/owner, if at the time of restarting, the SUNDOWN equipment is found to be in working order, this warranty shall continue to be in force for the remaining period of the warranty.
 - c) Damage to the SUNDOWN equipment or any part thereof caused during shifting or transportation is not covered by this warranty
 - 13) None of the company representative or authorized dealer is authorized to alter/amend any terms and conditions of this warranty policy. Only the management of the company is authorized to do so. The decision of the company will be final and binding to the purchaser.
 - 14) This warranty policy shall be governed by and construed in accordance with the laws of India and the courts in Rajkot shall have exclusive jurisdiction.
-

LIGHT POWER HARROW

- 15) This warranty is given in lieu of all other guarantees and condition expressed or implied by law or by the any person purporting to act on behalf of the company and excludes every condition, warranty or guarantee not herein expressly set out.

Note: The parts/material those are not covered by this warranty are as follows:

1. Blades
2. Universal joint cross
3. Paint
4. Bearings
5. Rubber parts
6. Gaskets
7. Fasteners
8. Fabrication

12. SPARE PARTS

All repairs and replacements on the machine must be performed only by using original spare parts, which must be obtained / provided from the manufacturer or your dealer.

This section contains the information needed to identify the parts of **LIGHT POWER HARROW** that may be ordered to manufacturer.

When request spare parts to manufacturer, always give following indications:

- Type of machine;
- Tiller serial number;
- Description and p/number of the spare parts;
- Quantities.

NOTE

For identification of p/numbers and description of safety decals refer to the Section Safety labels.

For identification of p/numbers and description of PTO driveline parts, refer to the manual of the driveshaft manufacturer.

The Manufacturer reserves the right to substitute a required part with an equivalent part, if applicable.

PARTS CATALOGUE

LIGHT POWER HARROW

POWER HARROW (LIGHT SERIES)

GEAR BOX ASSEMBLY

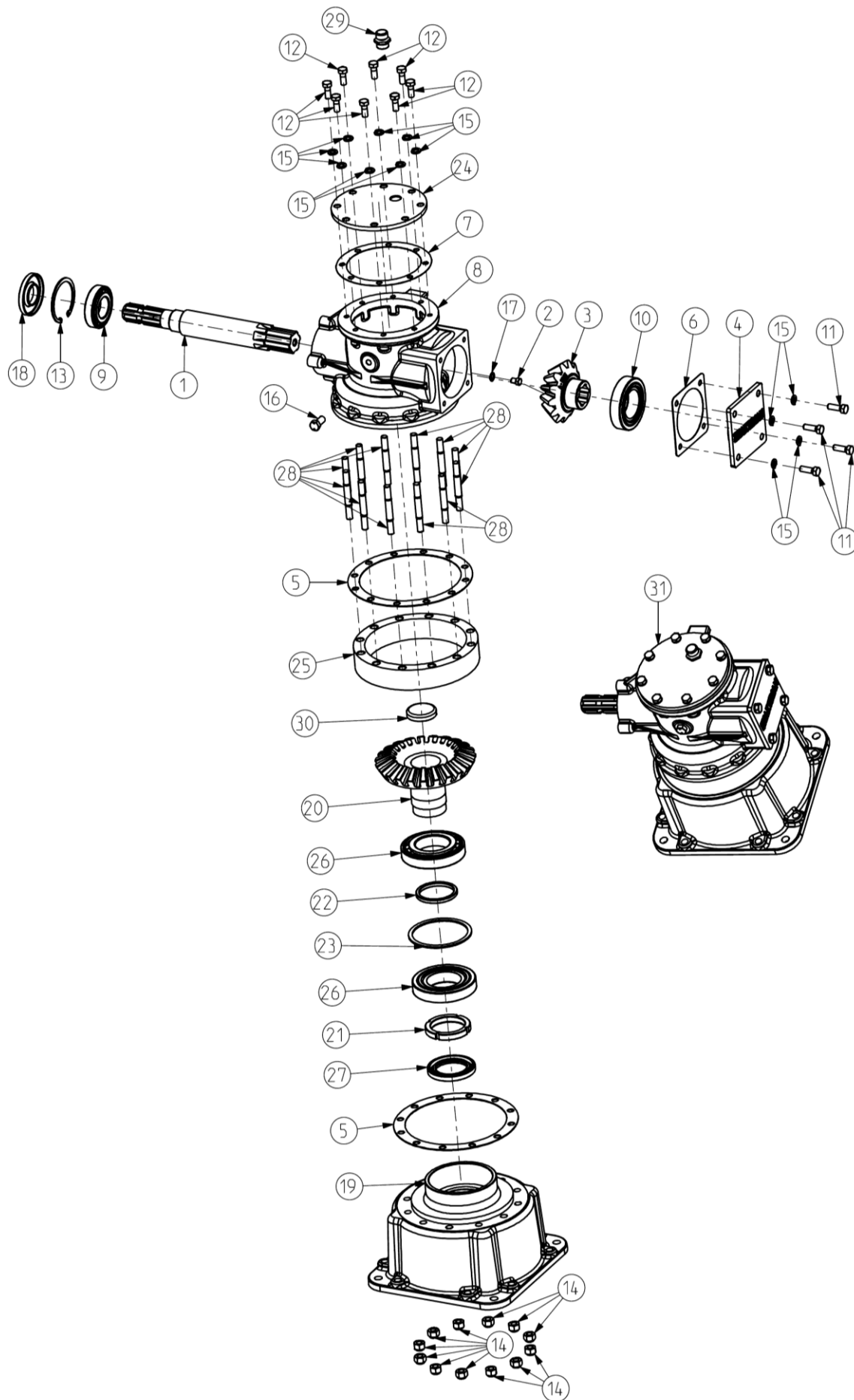

POWER HARROW (LIGHT SERIES)

GEAR BOX ASSEMBLY			
ITEM	MANUAL CODE	DESCRIPTION	QUANTITY
1	2004	INPUT SHAFT 540 RPM (CHA)	1
2	1012	CHAIN COVER DRAIN CAP	1
3	2005	PINION 13 TEETH (CHA)	1
4	2035	SHAKTIMAN BACK PLATE SMALL (CHA)OLD	1
5	2018	HOUSING FLANGE BIG GASKET (CHA) 0.4MM	As per Req.
	2104	HOUSING FLANGE BIG GASKET (CHA) 0.8MM	
	2105	HOUSING FLANGE BIG GASKET (CHA) 1.5MM	
6	2012	INTER. SHAFT PLATE GASKET (CHA)0.4 mm	As per Req.
	2106	INTER. SHAFT PLATE GASKET (CHA)0.8 mm	
	2107	INTER. SHAFT PLATE GASKET (CHA)1.5 mm	
7	1333	HOUSING FLANGE BIG GASKET (REG)0.8mm	1
8	2009	GEAR BOX 540 RPM (CHA)NEW	1
9	1022	BEARING 30208	1
10	1030	BEARING 32211	1
11	10181	HEX BOLT M10 X 1.50 X 30	4
12	10180	HEX BOLT M10 X 1.50 X 25	8
13	1130	CIRCLIP INTERNAL 80mm	1
14	1209	NYLOCK NUT M12X1.75 (DIN-982)	12
15	1304	SPRING WASHER 10mm	12
16	1310	HEX BOLT M12 X 1.50 X 25	1
17	1312	PLAIN WASHER 1/8 ALU.	2
18	2003	OIL SEAL 35 X 80 X 10	1
19	7016	GEAR BOX HOUSING BOTTOM (SRP)	1
20	7010	CROWN 23 TEETH (SRP)	1
21	7014	CROWN NUT M65 X 2 (SRP)	1
22	7012	CROWN MIDDLE INNER SPACER (SRP)	1
23	7013	CROWN MIDDLE OUTER SPACER (SRP)	1
24	7080	GEAR BOX TOP PLATE 540 RPM	1
25	7093	GEAR BOX SPACER (SRP-75)	1
26	7011	BEARING 30213	2
27	7123	OIL SEAL 62 x 90 x 10	1
28	7079	STUD M12 X 1.75 X 100	12
29	14310	AIR BREATHER 1/2" BSP (1GTSR38)	1
30	7122	CROWN CAP RUBBER COATED (SRP)	1
31	7209	GEAR BOX SINGLE SPEED ASSY(SRP)	1

POWER HARROW (LIGHT SERIES)

POWER HARROW HULL DRIVE

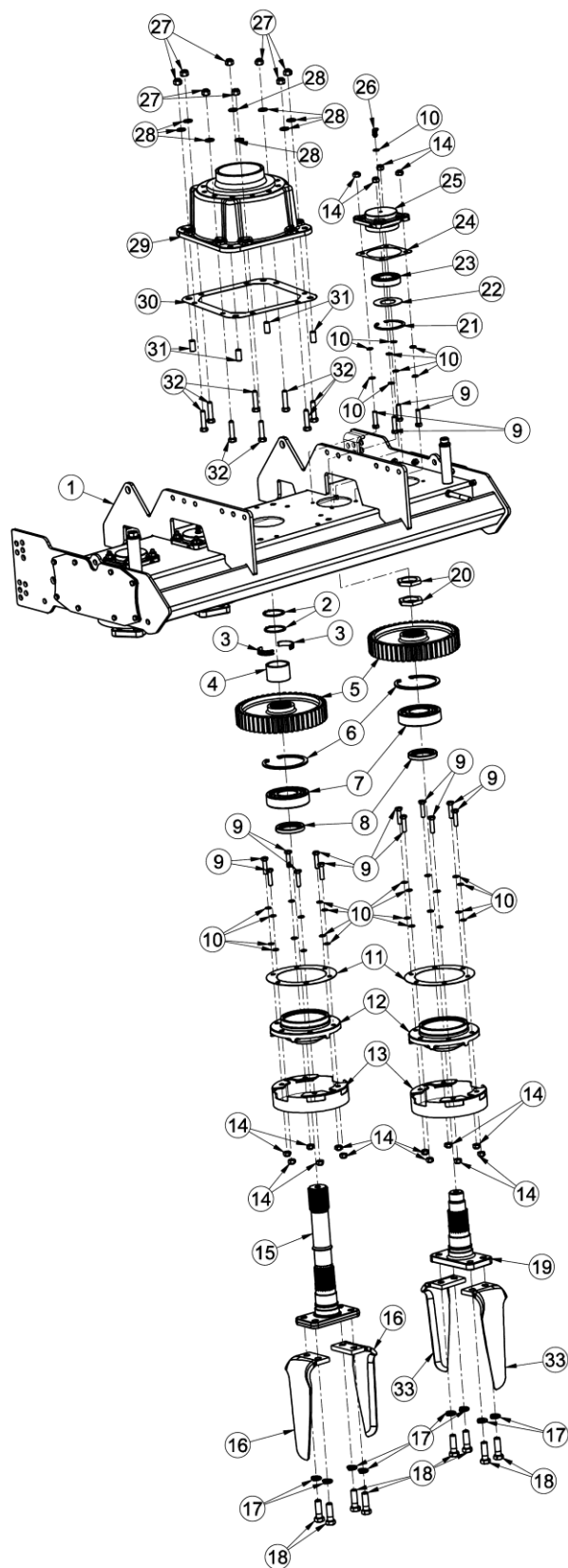

POWER HARROW (LIGHT SERIES)

POWER HARROW HULL DRIVE			
ITEM	MANUAL CODE	DESCRIPTION	QUANTITY
1	7281	HULL COMPLETE (SRP-125 L)	1
	7277	HULL COMPLETE (SRP-150 L)	1
	7283	HULL COMPLETE (SRP-175 L)	1
	7285	HULL COMPLETE (SRP-200 L)	1
2	7020	CIRCLIP EXTERNAL 55MM	2
3	7021	STOPPER HALF ROUND BUSH (SRP)	2
4	7022	STOPPER PLAIN BUSH (SRP)	1
5	7023	GEAR 49 TEETH (SRP)	5/6/7/8
6	1103	CIRCLIP INTERNAL 120MM	5/6/7/8
7	1102	BEARING 6311 LU	5/6/7/8
8	7025	OIL SEAL 60 X 80 X 10	5/6/7/8
9	7118	HEX BOLT M10 X 1.50 X 40 (FT)	46/56/66/76
10	1312	PLAIN WASHER 1/8 ALU.	96/117/138/159
11	7024	ROUND HOUSING GASKET (SRP)	5/6/7/8
12	7026	HOUSING BIG (6311) (SRP)	5/6/7/8
13	7280	STONE PROTECTION COVER COMP (SRP)	5/6/7/8
14	1298	NYLOCK NUT M10X1.50 (DIN-982)	46/56/66/76
15	7028	MAIN DRIVE SHAFT (SRP)	1
16	7030	BLADE LH (SRP) INDIAN	6/6/6/8
17	1308	SPRING WASHER 16mm	20/24/28/32
18	7039	HEX BOLT M16 X 1.50 X 50 (HT-10.9)	20/24/28/32
19	7036	SECONDARY DRIVE SHAFT (SRP)	4/5/6/7
20	7035	CASTLE NUT 45mm (SRP)	8/10/12/14
21	1130	CIRCLIP INTERNAL 80MM	4/5/6/7
22	7034	SPACER 80 X 42 X 1.50 (SRP)	4/5/6/7
23	7033	BEARING 6208	4/5/6/7
24	7032	SQ HOUSING GASKET SMALL (SRP)	4/5/6/7
25	7031	HOUSING SMALL (6208) (SRP)	4/5/6/7
26	1241	CONICAL HEAD GREASE NIPPLE M8 X 1	4/5/6/7
27	1209	NYLOCK NUT M12X1.75 (DIN-982)	8
28	8126	PLAIN WASHER 12mm	8
29	7016	GEAR BOX HOUSING BOTTOM (SRP)	1
30	7017	SQ HOUSING GASKET BIG (SRP)	1
31	7019	DOWELL PIN (SRP)	4
32	7134	HEX BOLT M12 X 1.75 X 50 (FT)	8
33	7029	BLADE RH (SRP) INDIAN	4/6/8/8

POWER HARROW (LIGHT SERIES)

TOP MAST / REAR LEVELING BAR & HULL PARTS

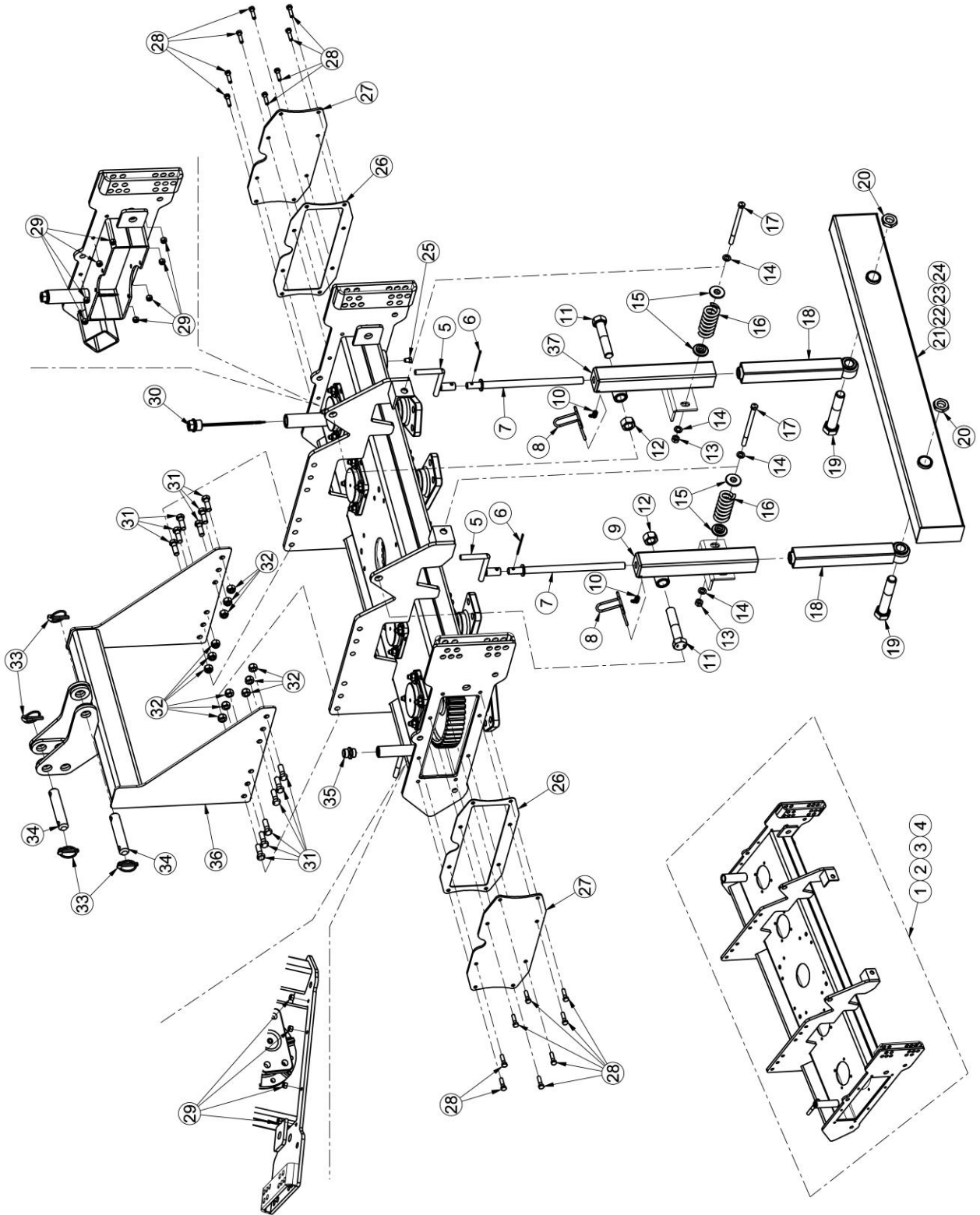

POWER HARROW (LIGHT SERIES)

TOP MAST / REAR LEVELING BAR & HULL PARTS			
ITEM	MANUAL CODE	DESCRIPTION	QUANTITY
1	7281	HULL COMPLETE (SRP-125 L)	1
2	7277	HULL COMPLETE (SRP-150 L)	1
3	7283	HULL COMPLETE (SRP-175 L)	1
4	7285	HULL COMPLETE (SRP-200 L)	1
5	7067	R.L. BAR SCREW HANDLE COMP(SRP)	2
6	1039	COTTER PIN (DIA 3 X 70mm)	2
7	7072	R.L. BAR SCREW COMP(SRP)	2
8	7066	R.L. BAR HANDLE HOOK (SRP)	2
9	7064	R.L. BAR OUTER PIPE RH COMP(SRP)	1
10	1241	CONICAL HEAD GREASE NIPPLE M8 X 1	2
11	7068	HEX BOLT M22 X 2.50 X 110	2
12	7119	HEX NUT M22 X 2.50	2
13	1298	NYLOCK NUT M10X1.50 (DIN-982)	2
14	8078	PLAIN WASHER 10mm	4
15	7071	R.L. BAR SPRING BUSH (SRP)	4
16	7070	R.L. BAR SPRING (SRP)	2
17	7121	HEX BOLT M10 X 1.50 X 150	2
18	7063	R.L. BAR INNER PIPE COMP(SRP)	2
19	7069	HEX BOLT M24 X 2 X 130	2
20	7120	HEX NUT M24 X 2	2
21	7282	REAR LEVELING BAR (SRP-125 L)	1
22	7278	REAR LEVELING BAR (SRP-150 L)	1
23	7284	REAR LEVELING BAR (SRP-175 L)	1
24	7286	REAR LEVELING BAR (SRP-200 L)	1
25	1012	CHAIN COVER DRAIN CAP	1
26	7057	HULL SIDE COVER GASKET (SRP)	2
27	7056	HULL SIDE COVER (SRP)	2
28	6072	HEX BOLT M8 X 1.25 X 30	16
29	1297	NYLOCK NUT M8X1.25 (DIN-982)	16
30	7075	HULL OIL LEVEL GAUGE COMP(SRP)	1
31	10194	HEX BOLT M12 X 1.75 X 35	12
32	1209	NYLOCK NUT M12X1.75 (DIN-982)	12
33	1218	LINCH PIN	4
34	7049	TOP MAST PIN (Dia25X130) (SRP)	2
35	14310	AIR BREATHER 1/2" BSP (1GTSR38)	1
36	7279	TOP MAST COMP (SRP L)	1
37	7065	R.L. BAR OUTER PIPE LH COMP(SRP)	1

POWER HARROW (LIGHT SERIES)

SLIDING PLATE AND BRACKET PARTS

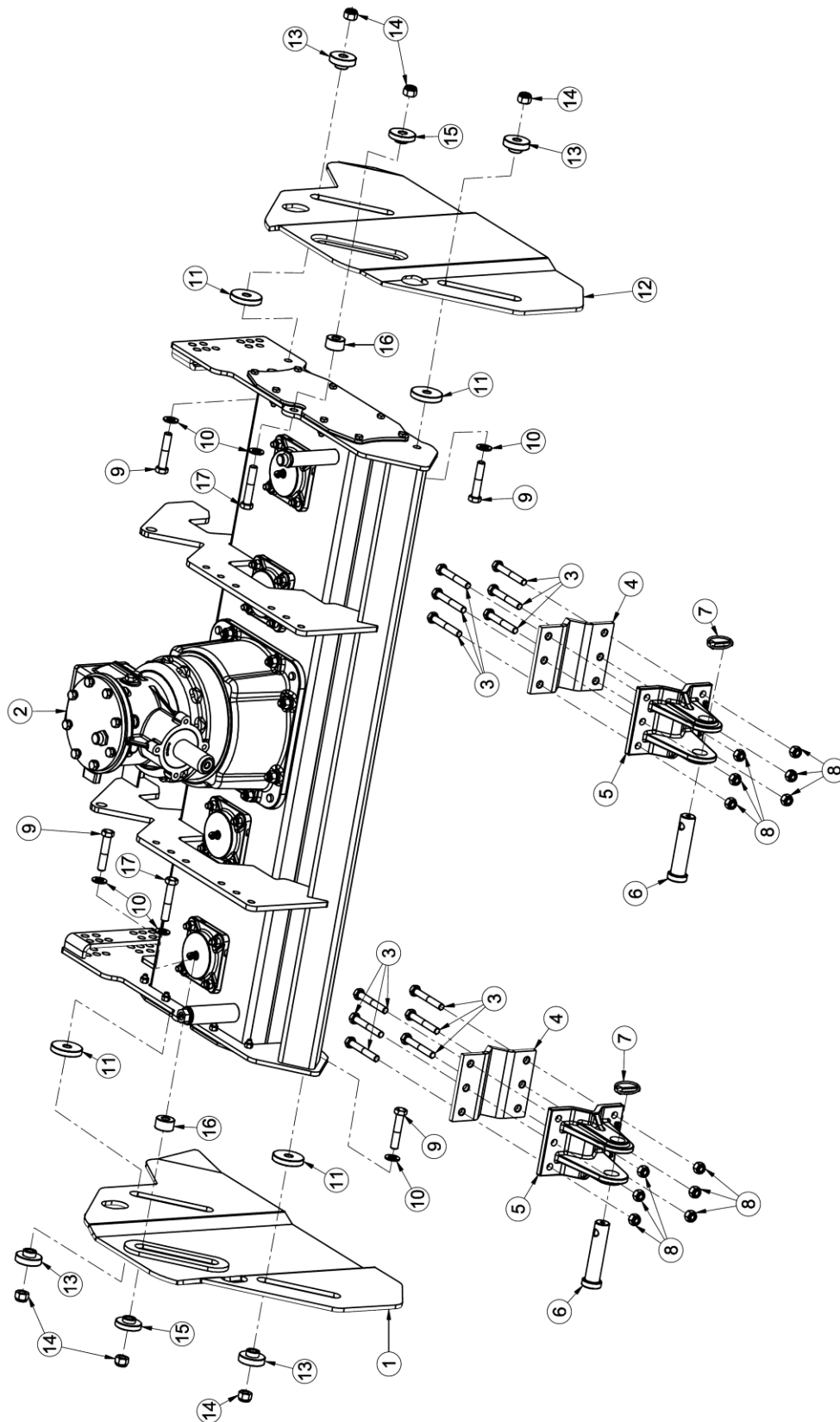

POWER HARROW (LIGHT SERIES)

SLIDING PLATE AND BRACKET PARTS			
ITEM	MANUAL CODE	DESCRIPTION	QUANTITY
1	7051	SLIDING PLATE RH COMPLETE (SRP)	1
2	7209	GEAR BOX SINGLE SPEED ASSY(SRP)	1
3	11572	HEX BOLT M12 X 1.75 X 90	12
4	1221	BRACKET ANGLE (REG)	2
5	1220	CASTING BRACKET (REG)	2
6	1217	HITCH PIN BOTTOM CAT-II (DIA-28 X 129)	2
7	1218	LINCH PIN	2
8	1209	NYLOCK NUT M12X1.75 (DIN-982)	12
9	7077	HEX BOLT M14 X 1.50 X 70	4
10	1272	PLAIN WASHER 14mm	6
11	7054	SLIDING PLATE PLAIN WASHER (SRP)	4
12	7050	SLIDING PLATE LH COMPLETE (SRP)	1
13	7052	SLIDING PLATE STEPPED BUSH BIG (SRP)	4
14	1302	NYLOCK NUT M14X1.50 (DIN-982)	6
15	7053	SLIDING PLATE STEPPED BUSH SMALL (SRP)	2
16	7055	SLIDING PLATE PLAIN BUSH (SRP)	2
17	18045	HEX BOLT M14 X 1.50 X 75	2

POWER HARROW (LIGHT SERIES)

PACKER ROLLER ASSEMBLY

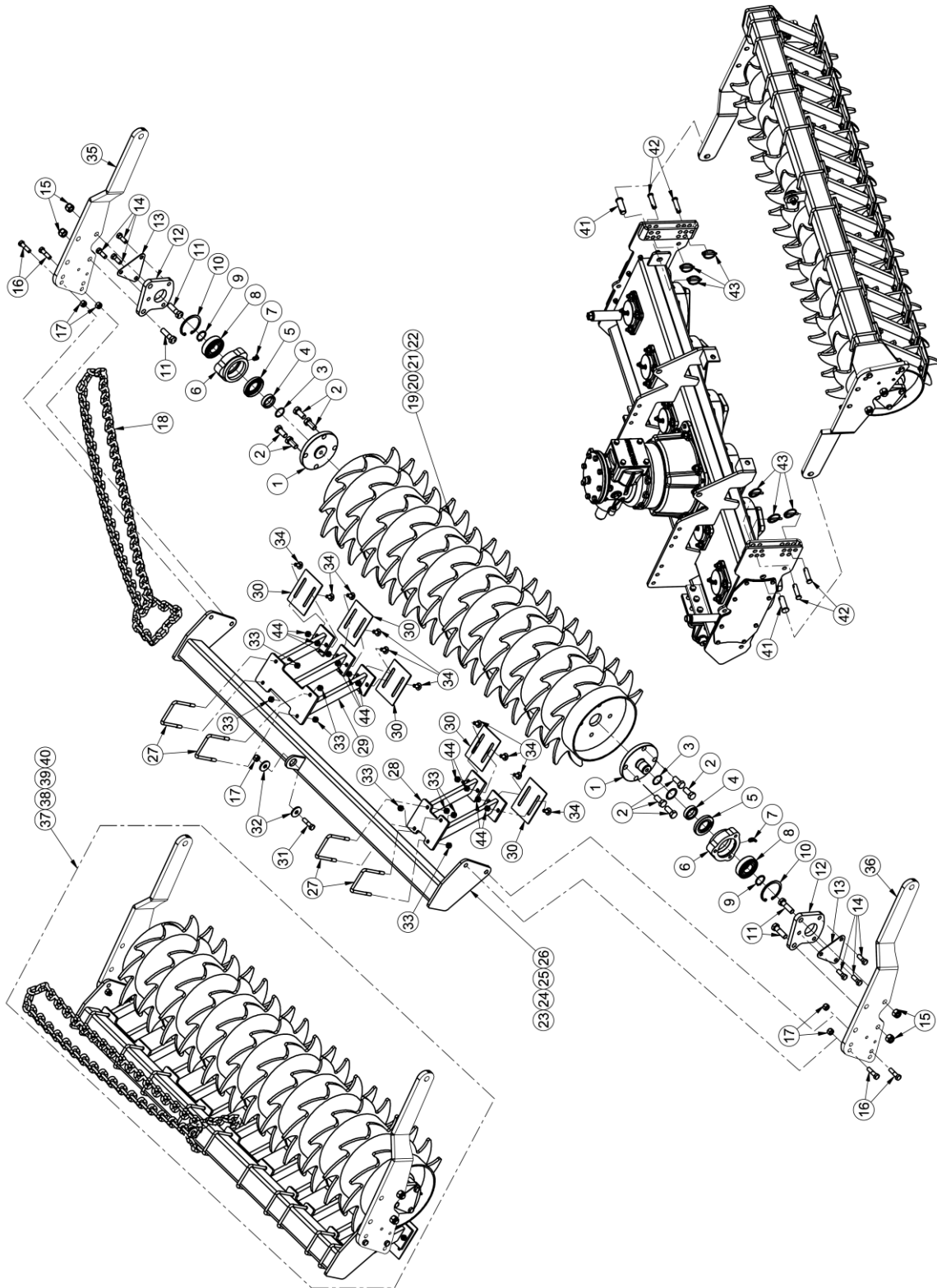

POWER HARROW (LIGHT SERIES)

PACKER ROLLER ASSEMBLY			
ITEM	MANUAL CODE	DESCRIPTION	QUANTITY
1	7082	PACKER ROLLER SHAFT (SRP)	2
2	1163	HEX BOLT M16 X 1.50 X 35 (FT)(10.9)	8
3	10087	O RING 32 X 3	2
4	1136	R D SLEEVE (MINI)	2
5	1135	MULTILIP OIL SEAL 45 X 78 X 11	2
6	7083	PACKER ROLLER SHAFT HOUSING (SRP)	2
7	1241	CONICAL HEAD GREASE NIPPLE M8 X 1	2
8	8043	BEARING 6307 2RS	2
9	6024	CIRCLIP EXTERNAL 35mm	2
10	1130	CIRCLIP INTERNAL 80mm	2
11	18446	HEX BOLT M16 X 2 X 55 (8.8)	4
12	7085	HOUSING MOUNTING PLATE (SRP)	2
13	7106	END COVER (SRP)	2
14	10194	HEX BOLT M12 X 1.75 X 35	6
15	1231	NYLOCK NUT M16X2.0 (DIN-982)	4
16	2594	HEX BOLT M12 X 1.75 X 45	4
17	1209	NYLOCK NUT M12X1.75 (DIN-982)	5
18	7135	LIFTING CHAIN (SRP)	1
19	7097	PACKER ROLLER COMPLETE (SRP-125)	1
20	7099	PACKER ROLLER COMPLETE (SRP-150)	1
21	7101	PACKER ROLLER COMPLETE (SRP-175)	1
22	7103	PACKER ROLLER COMPLETE (SRP-200)	1
23	7272	PACKER ROLLER SCRAP PIPE COMP. (SRP-125)	1
24	7271	PACKER ROLLER SCRAP PIPE COMP. (SRP-150)	1
25	7270	PACKER ROLLER SCRAP PIPE COMP. (SRP-175)	1
26	7269	PACKER ROLLER SCRAP PIPE COMP. (SRP-200)	1
27	23227	SQ.BEND U-BOLT M10X1.25X91X112X25 T.L	8/10/10/12
28	7262	SCRAPPER MOUNT PLATE DOUBLE COMP. (SRP)	1/2/0/1
29	7263	SCRAPPER MOUNT PLATE TRIPPLE COMP. (SRP)	3/3/5/5
30	23271	SCRAPER PLATE, PACKER ROLLER	11/13/15/17
31	2594	HEX BOLT M12 X 1.75 X 45	1
32	19180	WASHER (DIA. 40 x 13 x 4)	2
33	6556	HEX NUT M10X1.25 DIN 934	16/20/20/24
34	8175	ROUND HEADED SQ.NECK BOLT M10 X 1.5 X 25	22/26/30/34
35	7086	PACKER ROLLER MOUNTING PLATE RH (SRP)	1
36	7087	PACKER ROLLER MOUNTING PLATE LH (SRP)	1
37	7126	PACKER ROLLER ASSEMBLY (SRP-125)	1
38	7127	PACKER ROLLER ASSEMBLY (SRP-150)	1
39	7128	PACKER ROLLER ASSEMBLY (SRP-175)	1
40	7129	PACKER ROLLER ASSEMBLY (SRP-200)	1
41	7073	PIN (Dia20X60) (SRP)	2
42	7074	PIN (Dia14X60) (SRP)	4
43	8204	LINCH PIN SMALL (CHO)	6
44	1299	HEX NUT M10 X 1.50	22/26/30/34

POWER HARROW (LIGHT SERIES)

SPIKE ROLLER ASSEMBLY

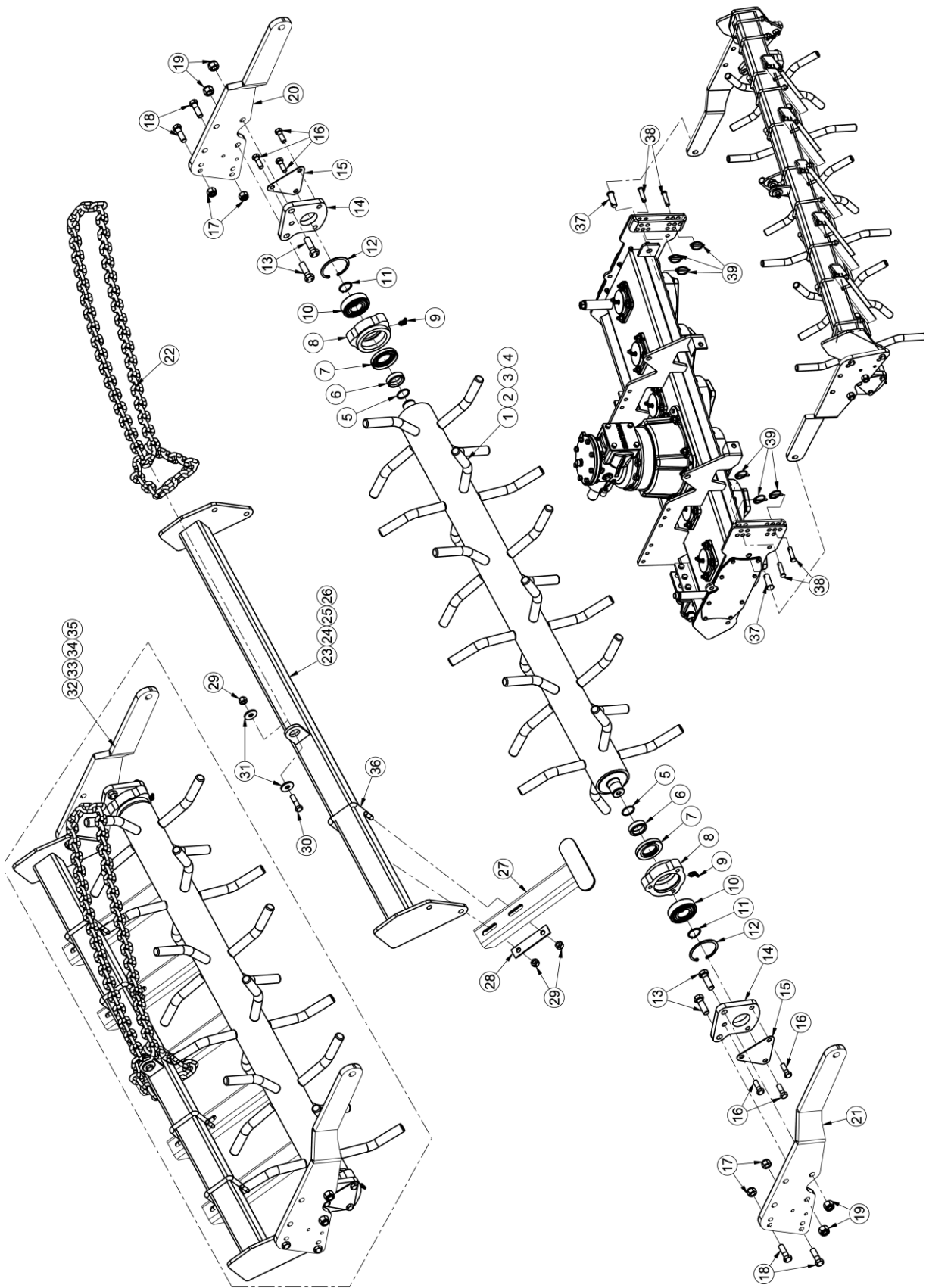

POWER HARROW (LIGHT SERIES)

SPIKE ROLLER ASSEMBLY			
ITEM	MANUAL sCODE	DESCRIPTION	QUANTITY
1	7167	SPIKE ROLLER COMP (SRP-125)	1
2	7170	SPIKE ROLLER COMP (SRP-150)	1
3	7173	SPIKE ROLLER COMP (SRP-175)	1
4	7176	SPIKE ROLLER COMP (SRP-200)	1
5	10087	"O" RING 32 X 3	2
6	1136	R D SLEEVE (MINI)	2
7	1135	MULTILIP OIL SEAL 45 X 78 X 11	2
8	7083	PACKER ROLLER SHAFT HOUSING (SRP)	2
9	1241	CONICAL HEAD GREASE NIPPLE M8 X 1	2
10	8043	BEARING 6307 2RS	2
11	6024	CIRCLIP EXTERNAL 35mm	2
12	1130	CIRCLIP INTERNAL 80mm	2
13	18446	HEX BOLT M16 X 2 X 55 (8.8)	4
14	7085	HOUSING MOUNTING PLATE (SRP)	2
15	7106	END COVER (SRP)	2
16	10194	HEX BOLT M12 X 1.75 X 35	6
17	1302	NYLOCK NUT M14X1.50 (DIN-982)	4
18	2594	HEX BOLT M12 X 1.75 X 45	4
19	1231	NYLOCK NUT M16 X 2	4
20	7086	PACKER ROLLER MOUNTING PLATE RH (SRP)	1
21	7087	PACKER ROLLER MOUNTING PLATE LH (SRP)	1
22	7135	LIFTING CHAIN (SRP)	1
23	7168	SPIKE ROLLER LEVELER COMP (SRP-125)	1
24	7171	SPIKE ROLLER LEVELER COMP (SRP-150)	1
25	7174	SPIKE ROLLER LEVELER COMP (SRP-175)	1
26	7177	SPIKE ROLLER LEVELER COMP (SRP-200)	1
27	7214	SPIKE ROLLER C-CHANNEL COMP (SRP)	4/5/6/7
28	7211	SPIKE ROLLER U-CLAMP PLATE (SRP)	4/5/6/7
29	1209	NYLOCK NUT M12 X 1.75	9/11/13/15
30	2594	HEX BOLT M12 X 1.75 X 45	1
31	25218	WASHER (37 X 13 X 4)	2
32	7169	SPIKE ROLLER ASSEMBLY (SRP-125)	1
33	7172	SPIKE ROLLER ASSEMBLY (SRP-150)	1
34	7175	SPIKE ROLLER ASSEMBLY (SRP-175)	1
35	7178	SPIKE ROLLER ASSEMBLY (SRP-200)	1
36	7210	SPIKE ROLLER U CLAMP (SRP)	4/5/6/7
37	7073	PIN (Dia20X60) (SRP)	2
38	7074	PIN (Dia14X60) (SRP)	4
39	8204	LINCH PIN SMALL (CHO)	6

POWER HARROW (LIGHT SERIES)

CAGE ROLLER ASSEMBLY

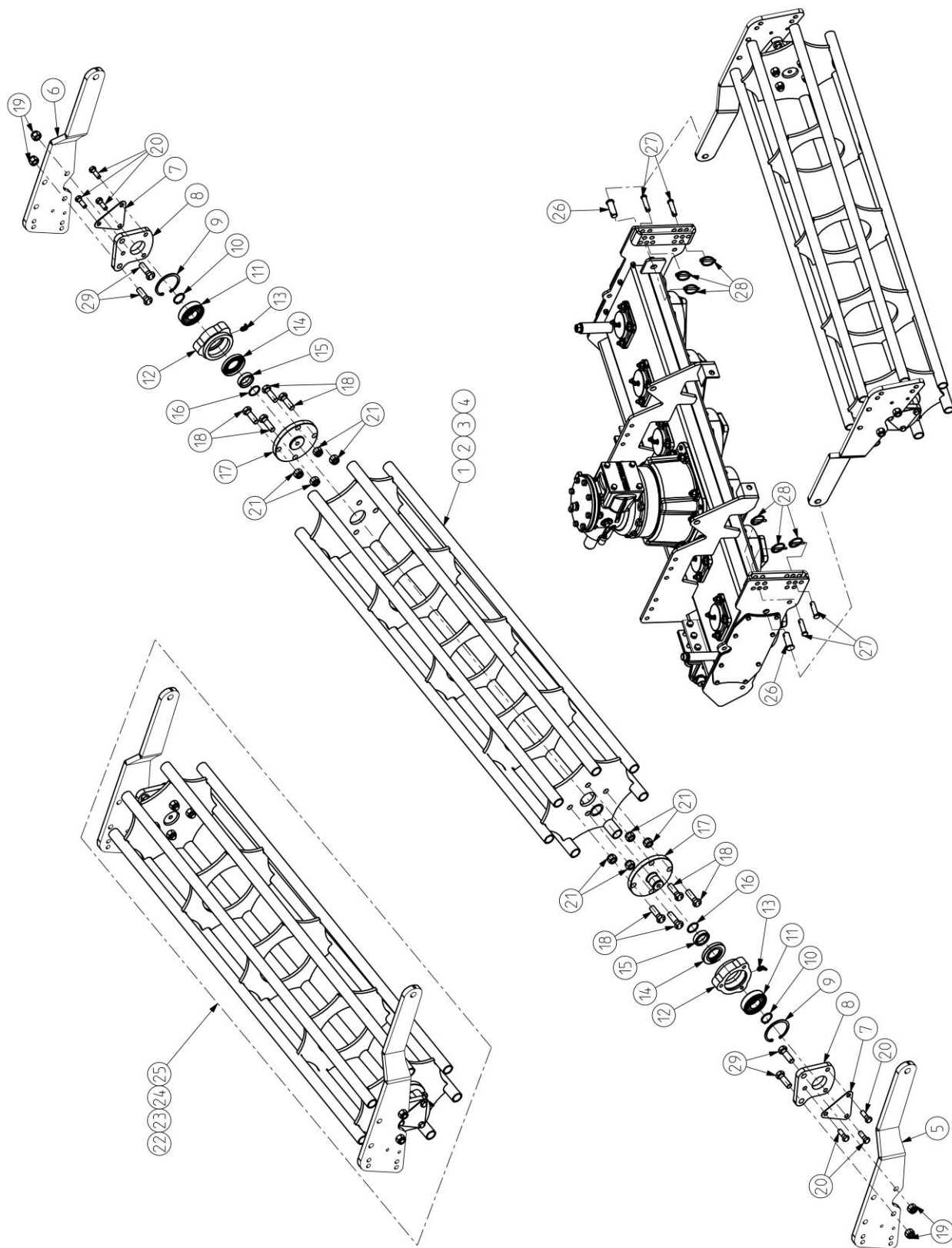

POWER HARROW (LIGHT SERIES)

CAGE ROLLER ASSEMBLY			
ITEM	MANUAL CODE	DESCRIPTION	QUANTITY
1	7192	CAGE ROLLER COMP. (SRP-125)	1
2	7194	CAGE ROLLER COMP. (SRP-150)	1
3	7215	CAGE ROLLER COMP. (SRP-175)	1
4	7196	CAGE ROLLER COMP. (SRP-200)	1
5	7087	PACKER ROLLER MOUNTING PLATE LH (SRP)	1
6	7086	PACKER ROLLER MOUNTING PLATE RH (SRP)	1
7	7106	END COVER (SRP)	2
8	7085	HOUSING MOUNTING PLATE (SRP)	2
9	1130	CIRCLIP INTERNAL 80mm	2
10	6024	CIRCLIP EXTERNAL 35mm	2
11	8043	BEARING 6307 2RS	2
12	7083	PACKER ROLLER SHAFT HOUSING (SRP)	2
13	1241	CONICAL HEAD GREASE NIPPLE M8 X 1	2
14	1135	MULTILIP OIL SEAL 45 X 78 X 11	2
15	1136	R D SLEEVE (MINI)	2
16	10087	"O" RING 32 X 3	2
17	7082	PACKER ROLLER SHAFT (SRP)	2
18	7108	HEX BOLT M16 X 2 X 50	8
19	1231	NYLOCK NUT M16X2.0 (DIN-982)	4
20	10194	HEX BOLT M12 X 1.75 X 35	6
21	1231	NYLOCK NUT M16X2.0 (DIN-982)	8
22	7193	CAGE ROLLER ASSEMBLY (SRP-125)	1
23	7195	CAGE ROLLER ASSEMBLY (SRP-150)	1
24	7206	CAGE ROLLER ASSEMBLY (SRP-175)	1
25	7197	CAGE ROLLER ASSEMBLY (SRP-200)	1
26	7073	PIN (Dia20X60) (SRP)	2
27	7074	PIN (Dia14X60) (SRP)	4
28	8204	LINCH PIN SMALL (CHO)	6
29	18446	HEX BOLT M16 X 2 X 55 (8.8)	4

POWER HARROW (LIGHT SERIES)

SHEAR BOLT PTO ASSEMBLY

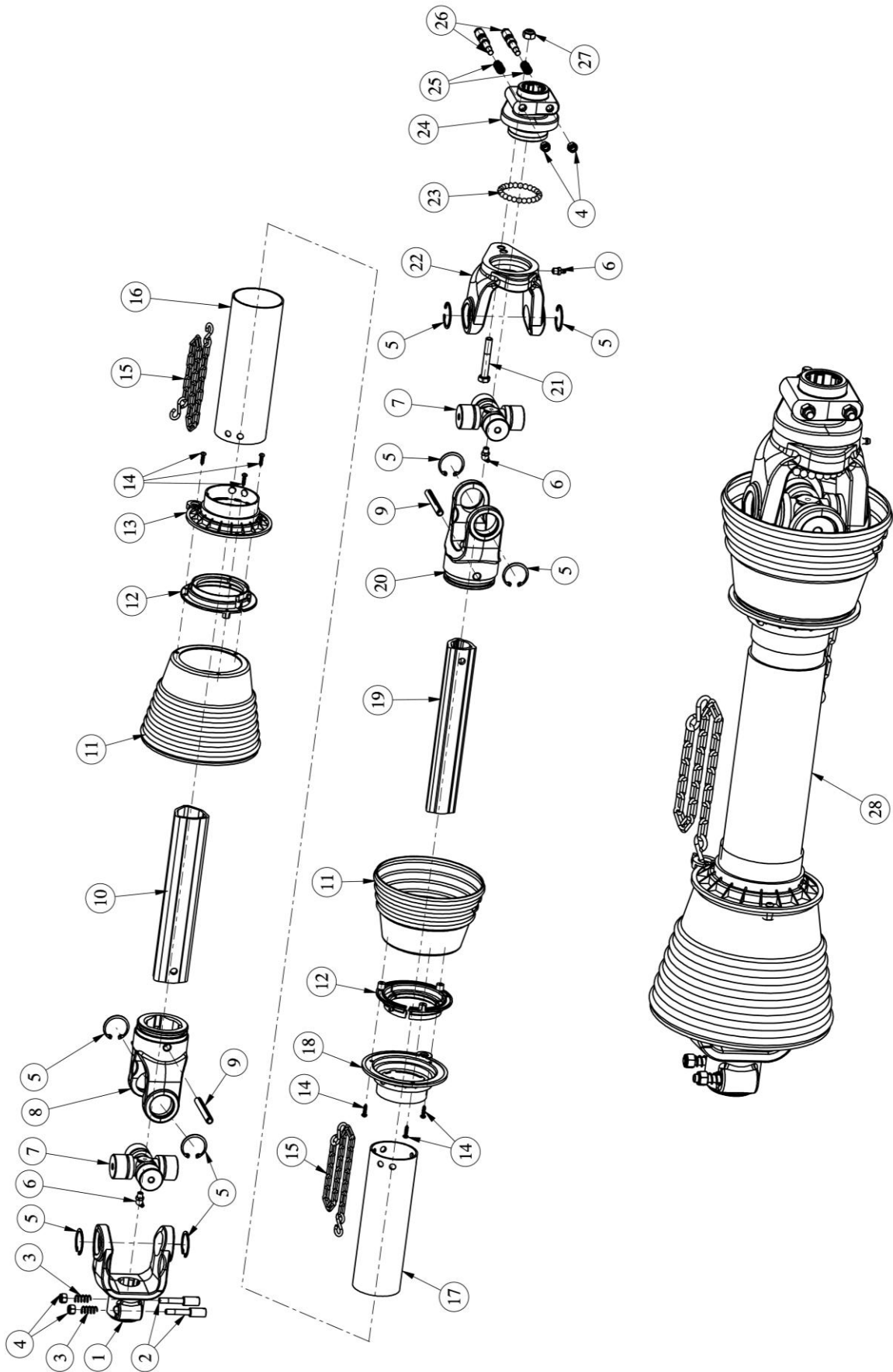

POWER HARROW (LIGHT SERIES)

SHEAR BOLT PTO ASSEMBLY			
ITEM	MANUAL CODE	DESCRIPTION	QUANTITY
1	1234	PLAIN YOKE 6-SPLINE	1
	1237	PLAIN YOKE 21-SPLINE	1
2	1257	PUSH PIN SMALL	2
3	1258	PUSH PIN SPRING SMALL	2
4	1297	NYLOCK NUT M8X1.25 (DIN-982)	4
5	1243	CIRCLIP INTERNAL 38mm	8
6	1253	1/8 BSP GREASE NIPPLE 7.5MM	3
7	1240	CROSS	2
8	1245	OUTER TUBE YOKE	1
9	1264	DOWEL PIN DIA 10 X 85	2
10	1353	OUTER TUBE 16.5"	1
11	1516	JOINT COVER CONE (NEW COVER)	2
12	1519	RETAINER COLLER (NEW COVER)	2
13	1517	OUTER PIPE COVER CAP (NEW COVER)	1
14	18358	SLOTTED HEAD SCREW M4 X 0.7 X20	6
15	1320	PTO CHAIN	2
16	1515	OUTER PIPE PLASTIC NEW (16.5")	1
17	1514	INNER PIPE PLASTIC NEW (16.5")	1
18	1518	INNER PIPE COVER CAP (NEW COVER)	1
19	1352	INNER TUBE 16.5"	1
20	1249	INNER TUBE YOKE	1
21	1261	HEX BOLT M10 X 1.50 X 65	1
22	1252	SHEAR BOLT YOKE	1
23	1263	STEEL BALLS SHEAR BOLT YOKE	24
24	1255	DOUBLE PIN HUB	1
25	1260	PUSH PIN SPRING BIG	2
26	1259	PUSH PIN BIG	2
27	1298	NYLOCK NUT M10X1.50 (DIN-982)	1
28	2131	SHEAR BOLT PTO 6SP COMP(COVER)16.5"	1
	2133	SHEAR BOLT PTO 21SP COMP(COVER)16.5"	1

POWER HARROW (LIGHT SERIES)

CLUTCH PTO ASSEMBLY

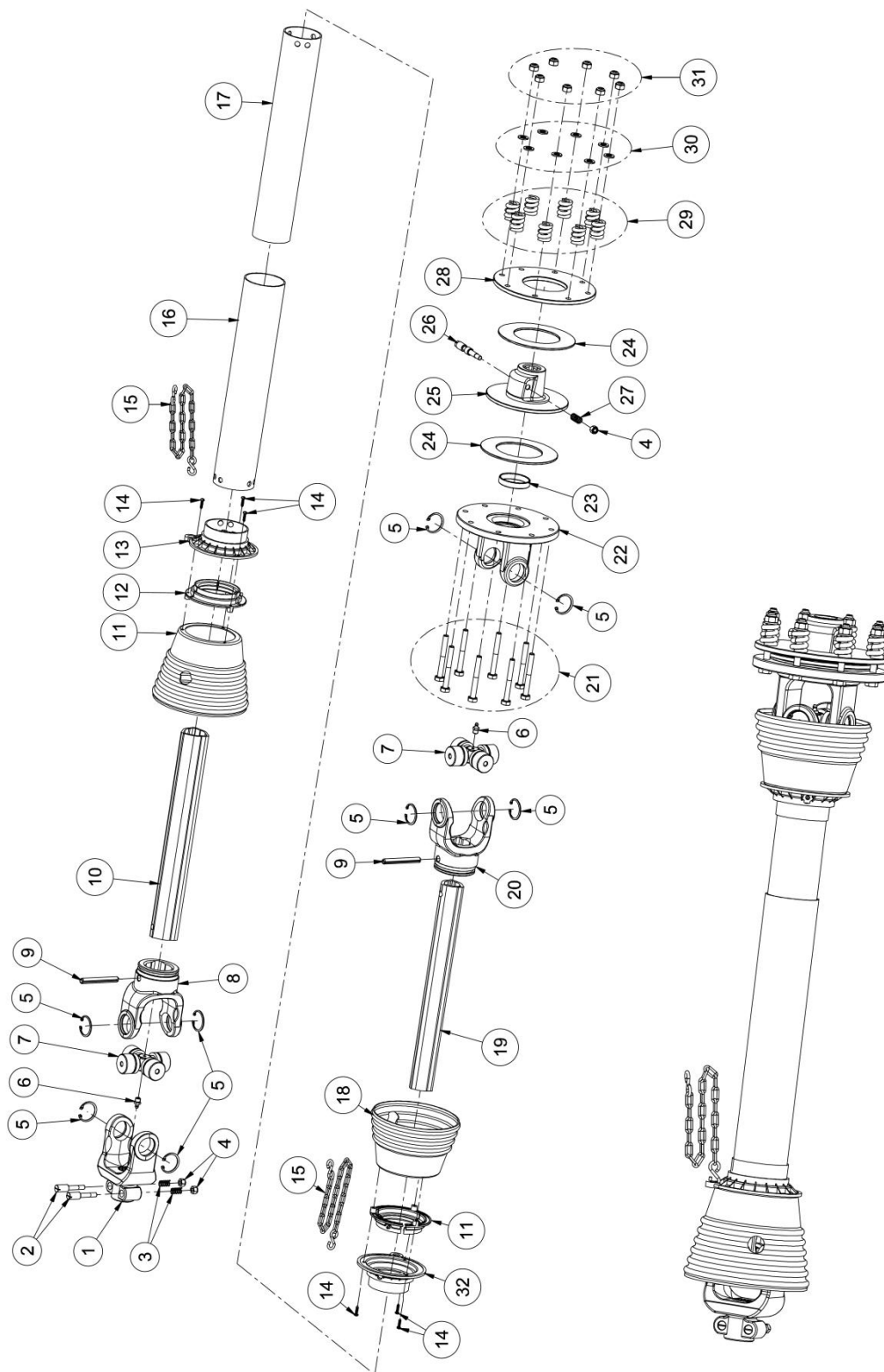

POWER HARROW (LIGHT SERIES)

CLUTCH PTO ASSEMBLY			
ITEM	MANUAL CODE	DESCRIPTION	QUANTITY
1	1237	PLAIN YOKE 21-SPLINE	1
2	1257	PUSH PIN SMALL	2
3	1258	PUSH PIN SPRING SMALL	2
4	1297	NYLOCK NUT M8X1.25 (DIN-982)	3
5	1243	CIRCLIP	8
6	1253	GREASE NIPPLE	2
7	1240	CROSS	2
8	1245	OUTER TUBE YOKE	1
9	1264	DOWEL PIN DIA 10 X 85	2
10	1353	OUTER TUBE 16.5"	1
11	1516	JOINT COVER CONE (NEW COVER)	1
12	1519	RETAINER COLLER (NEW COVER)	2
13	1517	OUTER PIPE COVER CAP (NEW COVER)	1
14	18358	SLOTTED HEAD SCREW M4 X 0.7 X20	6
15	1320	PTO CHAIN	2
16	1515	OUTER PIPE PLASTIC NEW (16.5")	1
17	1514	INNER PIPE PLASTIC NEW (16.5")	1
18	1588	JOINT COVER CONE (NEW COVER)SPECIAL	1
19	1352	INNER TUBE 16.5"	1
20	1249	INNER TUBE YOKE	1
21	26034	HEX BOLT M10 X 1.50 X 85	8
22	1284	CLUTCH YOKE	1
23	1285	CLUTCH YOKE SLEEVE	1
24	1289	FRICITION PLATE	2
25	1286	6-SPLINE HUB (CLUTCH TYPE)	1
26	1259	PUSH PIN BIG	1
27	1260	PUSH PIN SPRING BIG	1
28	1287	CLUTCH YOKE PLAIN WASHER	1
29	5026	SPRING 27 X 7 X 32	8
30	8078	PLAIN WASHER 10MM	8
31	1298	NYLOCK NUT M10X1.50 (DIN-982)	8
32	1518	INNER PIPE COVER CAP (NEW COVER)	1

POWER HARROW (LIGHT SERIES)

CE GUARD ASSEMBLY

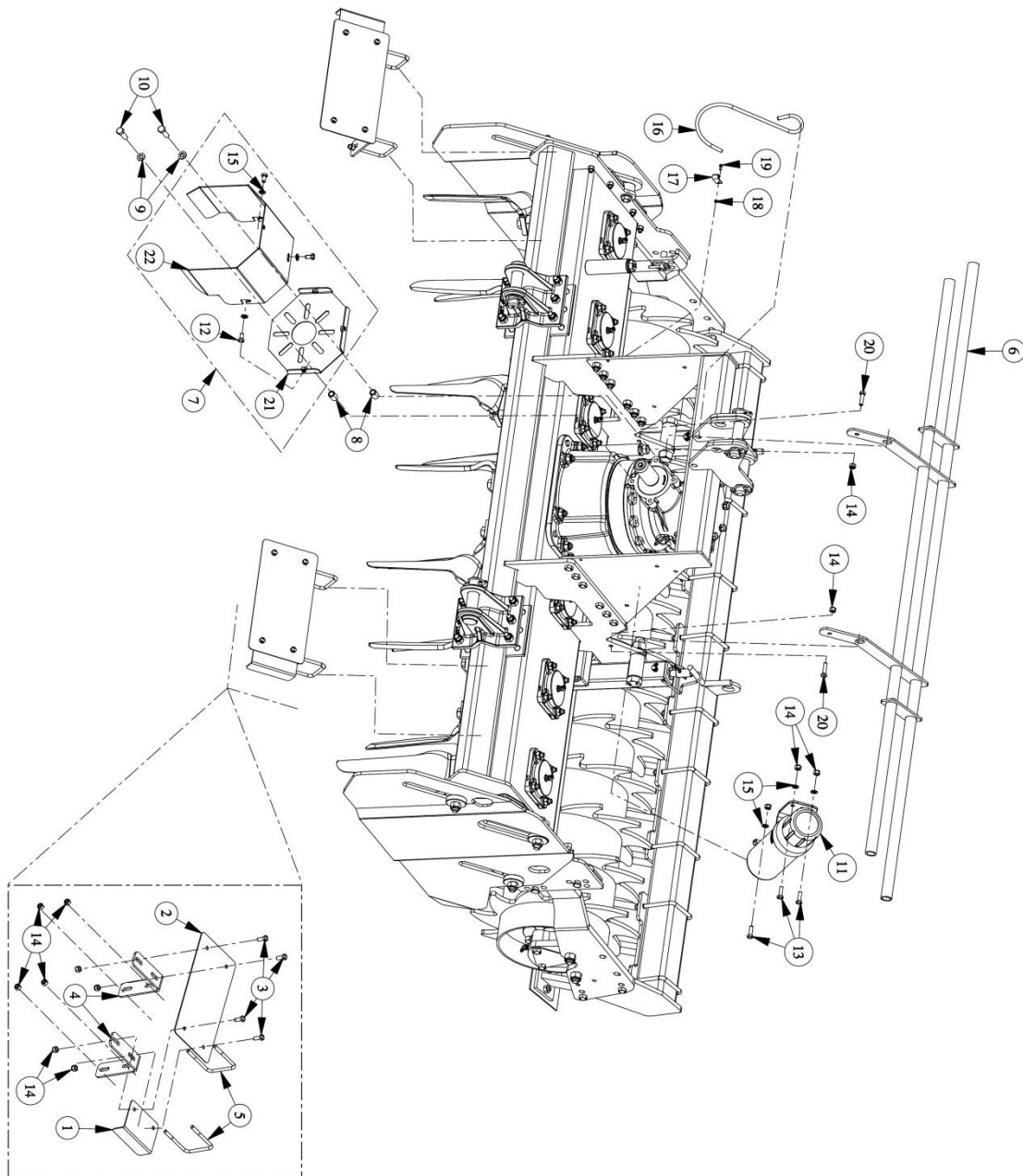

POWER HARROW (LIGHT SERIES)

CE GUARD ASSEMBLY			
SR NO	MANUAL CODE	DESCRIPTION	QTY
1	3321	PLATE,END,FRONT BARRIER (CHA)	2
2	3316	PLATE,FRONT BARRIER (L=100) (CHA)	(SRP-125)-2
			(SRP-150)-1
	3317	PLATE,FRONT BARRIER (L=300) (CHA)	(SRP-150)-1
			(SRP-175)-2
3	8040	HEX BOLT M8 X 1.25 X 20	(SRP-200)-3
			(SRP-125)-4
			(SRP-150)-6
			(SRP-175)-8
4	4731	BRACKET,FRONT BARRIER (REG + & L)	(SRP-200)-12
			(SRP-125)-2
			(SRP-150)-3
			(SRP-175)-4
5	3260	SQ BEND U-BOLT M8X1.25X75X92X30TL	(SRP-200)-6
			(SRP-125)-2
			(SRP-150)-3
			(SRP-175)-4
6	7327	REAR GUARD COMP (SRP-125) LIGHT	1
	7328	REAR GUARD COMP (SRP-150) LIGHT	
	7329	REAR GUARD COMP (SRP-175) LIGHT	
	7330	REAR GUARD COMP (SRP-200) LIGHT	
7	1547	PTO SHAFT GUARD ASSEMBLY	1
8	1417	JOINT COVER MOUNTING BUSH	2
9	8078	PLAIN WASHER 10MM (BS-4320)	2
10	6068	HEX BOLT M10 X 1.50 X 35	2
11	26030	MANUAL BOX COVER 1/2(SMMSD)	1
12	8190	HEX BOLT M8 X 1.25 X 15	3
13	8171	HEX BOLT M8 X 1.25 X 25	3
14	1297	NYLOCK NUT M8X1.25 (DIN-982)	(SRP-125)-13
			(SRP-150)-17
			(SRP-175)-21
			(SRP-200)-29
15	8064	PLAIN WASHER 8MM (BS-4320)	6
16	14340	DRIVELINE HOOK 250MM	1
17	23147	PLATE,HOOK HOLDING (JUMBO)	1
18	23028	HEX NUT M4 X 0.75	1
19	23029	HEX BOLT M4 X 0.75 X 10	1
20	19196	HEX BOLT M8 X 1.25 X 30 (FT)(8.8)	2
21	1546	PTO SHAFT GUARD MOUNT PLATE COMP	1
22	17558	PTO SHAFT GUARD (BMF)	1

NOTES:

.....

...

.....

...

.....

...

.....

...

.....

...

.....

...

.....

...

.....

...

.....

...

.....

...

.....

...

.....

...

.....

...

.....

...

.....

...

.....

...

.....

...

.....

...



J.S. Woodhouse Co., Inc.

1314 Union Street

West Springfield, MA 01089

Tel: 413-736-5462

FAX 413- 732-3786